

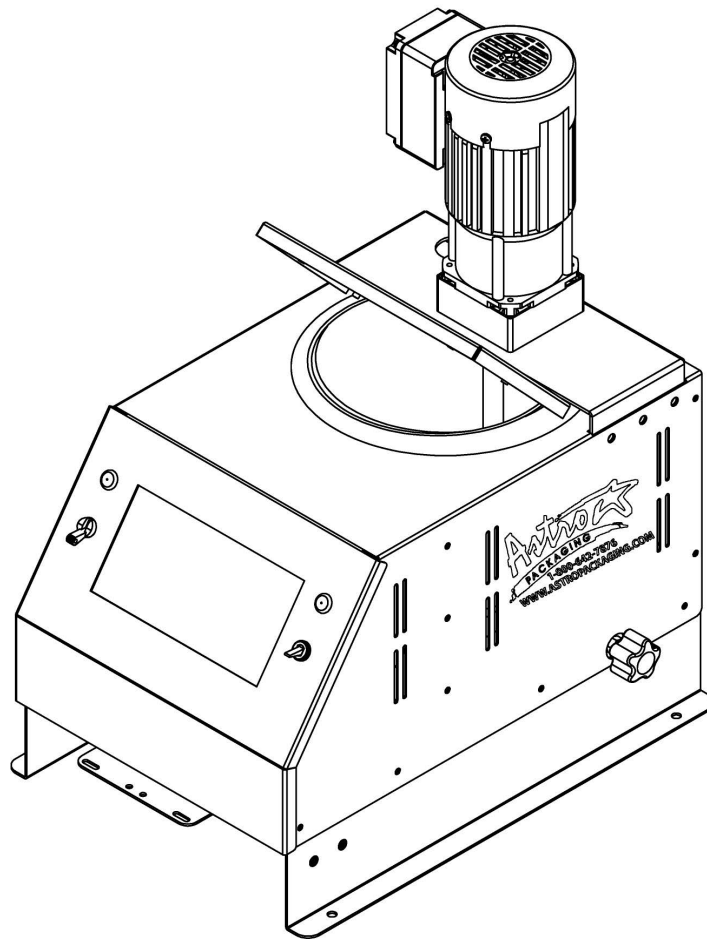

SS10 HOT MELT UNIT MANUAL

Manual Number: 19600-17-SS10 REV B

For More Information Please Contact
Technical Support: 800-642-7876



CONTACT INFORMATION

PHONE NUMBERS 630-250-0700
800-419-GLUE (4583)

WEBSITE AND CUSTOMER PORTAL www.chicagoglue.com

ORDERS orders@chicagoglue.com

INFORMATION & QUOTES info@chicagoglue.com

ACCOUNTING payables@chicagoglue.com

EQUIPMENT TECHNICAL SUPPORT service@chicagoglue.com

FOLLOW US FOR COMPANY UPDATES



**CHICAGO
GLUE & MACHINE**



SAFETY PRECAUTIONS

GENERAL CONSIDERATIONS

1. Read and follow these instructions. Failure to do so could result in severe personal injury or death.
2. Additional safety instructions and/or symbols are located throughout this manual. They serve to warn maintenance personnel and operators about potentially hazardous situations.
3. Inspect the machine for unsafe conditions daily and replace all worn or defective parts.
4. Keep work area uncluttered and well lit.
5. All covers and guards must be in place before operating this equipment.

For precautions and definitions of safety symbols, refer to Chapter 1, Safety Precautions, of the service manual.

SERVICING EQUIPMENT

1. Only trained personnel are to operate and service equipment.
2. Never service equipment while it is in operation.
3. Shut off the equipment and lock out all input power and air supply at their sources before attempting any maintenance.
4. Follow the maintenance and service instructions in the manual.

SIGNS

1. Read and obey all of the warning labels, signs and caution statements on the equipment.
2. Do not remove or deface any of the warning labels, signs, and caution statements on the equipment.
3. Replace any warning labels, signs, and caution statements which have been removed or defaced. Replacements are available.

ADDITIONAL CONSIDERATIONS

1. To ensure proper operation of the equipment, use specified electrical and/or air supply sources.
2. Do not attempt to alter the design of the equipment unless written approval is received from our factory.
3. Keep all manuals readily accessible at all times and refer to it often for the best performance from your equipment.



TABLE OF CONTENTS

Chapter 1 Safety Precautions	Chapter - Page #
Chapter 2 Description & Specifications	
Description	2 - 1
Features	2 - 1
Specifications	2 - 2
Motor Speed, Adhesive Pressure, and Flow Rate	2 - 2
Dimensions	2 - 3
Chapter 3 Installation & Start Up	
Installation	3 - 1
Component Installation	3 - 1
Start-Up	3 - 3
Adding Adhesive	3 - 3
Changing Adhesive Formula	3 - 3
Adjusting the Flow Control Valve	3 - 4
Storage & Disposal of the Application System	3 - 5
Chapter 4 TC 500 Temperature Controller (K1 Software) Set-Up	
Programming Temperature Set-points	4 - 1
Set Offset Temperature	4 - 2
Set Automatic Wakeup	4 - 3
Set Clock Calendar	4 - 3
Save and Register Setting	4 - 4
Display/Set Audit Variables	4 - 4
Performance Various Maintenance Tasks	4 - 5
Performance Various System Tasks	4 - 7
Security Lock Level	4 - 8

Chapter 5 Preventive Maintenance

Maintenance 5 - 1
Preventive Maintenance 5 - 1
Flushing your system 5 - 2

Chapter 6 Troubleshooting

General Troubleshooting 6 - 1
Tank does not heat 6 - 1
Zone Over-temperature 6 - 1
Applicator and Hose Heat Slowly 6 - 1
Motor does not turn 6 - 2
Applicator and Hose Fail to Heat 6 - 2
Adhesive Output Levels 6 - 2

Chapter 7 Repair & Replacement

Hose Replacement 7 - 1
Tank Heater Replacement 7 - 3
Tank RTD Sensor Replacement 7 - 4
Tank Over-temperature Thermostat Replacement 7 - 5
Flow Control Block Replacement 7 - 6
Pump Motor and Pump Shaft Replacement 7 - 7

Chapter 8 Component Illustration and Bill of Materials

Recommended Spare Parts 8 - 1

Optional Accessories 8 - 1

Tank Components 8 - 2

Motor & Mounting Hardware 8 - 4

Pump Group 8 - 6

Flow Control Group 8 - 8

TC500 Circuit Board 8 - 10

TC500 Fuses 8 - 11

TC500 Connections 8 - 12

Exterior Panel & Control Parts List 8 - 14

Chapter 9 Component Illustrations

Resistance Tables 9 - 1

Motor Wiring Diagram..... 9 - 3

Wiring Diagram 120 V Unit 9 - 4

Wiring Diagram 240 V Unit 9 - 5

Chapter 1

Safety Precautions

This manual contains important safety information and instructions. Failure to comply with these instructions can result in death, injury, or permanent damage to this equipment and will void the warranty.

Intended Use

This equipment is designed for use with standard adhesive and sealant materials with flash points above 232 °C (450 °F). Use of flammable material or material not compatible with the specifications of this equipment can cause injury to operator and damage to equipment. The manufacturer has designed this equipment for safe operation. Specified models are in compliance with EN 60204-1:1997. However, heated thermoplastics and other hot melt materials are dangerous and care must be exercised to ensure operational safety. Handling must be in accordance with hot melt manufacturer specifications. Never exceed the maximum application temperature recommended by the adhesive manufacturer. Dispose of hot melt properly. Refer to the Materials Safety Data Sheet (MSDS) of the hot melt for recommended disposal methods.

Personal Safety

Wear the following protection when working on or around this equipment:



Always wear heat resistant gloves rated to 205 °C (400 °F) and allow all system temperatures to stabilize below 193 °C (380 °F) before servicing. Properly ventilate equipment according to MSDS of equipment. Trained operators and service technicians should be aware of exposed surfaces of the unit that cannot be practically safeguarded. These exposed surfaces may be hot and take time to cool after the unit has been operating. Keep parts of the body away from rotating parts. Do not wear loose Safety Gloves or articles of clothing when operating or servicing units with rotating parts. Remove wristwatches, rings, necklaces, or other jewelry and cover or pin up long hair before performing any work on or with the unit. Trained operators may perform only external equipment adjustments. Trained service technicians must perform internal adjustments and services.

Electrical Safety

Determine voltage of this equipment before installation and confirm compatibility with available power. Equipment must be connected to a properly grounded circuit and installed in accordance with all applicable electrical codes. Ground fault protection must be provided in supply circuitry at site installation. Models designed to EN60204-1: 1997 require power cords be approved to a harmonized (HAR) standard and rated for 70 °C (158 °F). A HAR approved Type B plug and strain relief for power cord are required to meet standard IEC 309. **Power conducting wires must be nominal 5.3 mm² (10 AWG) maximum and nominal 2.1 mm² (14 AWG) minimum.**

Emergency Power Disconnect

In the event of a malfunction, turn off power to the equipment at the power off switch and remove power source to the system at the nearest main disconnect.



Follow Directions

Read the product manual thoroughly before installation, operation, or maintenance. Failure to do so can result in a serious accident or equipment malfunction. The manufacturer will not be held liable for injuries or damage caused by misuse of this equipment or for any other uses other than intended by Astro Packaging.





Safety Symbols and Signal Words

The following safety symbols and signal words are used throughout the manual and on the product to alert the reader and operator to personal safety hazards or to identify conditions that may result in equipment or property damage.





















General Safety Symbols

	CAUTION: Indicates a hazard, which, if not avoided, can result in minor injury, or equipment and property damage.
	WARNING: Indicates a hazard, which if not avoided, can result in serious injury, or equipment and property damage.
	DANGER: Indicates a hazard, which, if not avoided, will result in serious injury, including death, or equipment and property damage.

Specific Symbols and Signal Words

	DANGER: High Voltage. Can cause serious injury, including death. Disconnect electrical power at external source before servicing.
	WARNING: Hot Surface. Can cause serious injury, including death. Disconnect electrical power
	WARNING: Disconnect electrical power at external source. Failure to do so can cause electrical shock.
	WARNING: High Pressure. System contents under pressure. Can cause serious injury and burns or equipment and property damage. Relieve pressure before servicing.

Other Product Symbols

			
On	Off	Ground	Protective Earth
			
Tank	Heated Hose	Applicator	Pump Motor
			
Set Temp	Standby Temp	Over-temp	Adhesive Flow
			
Tank Heater	Alarm	Actual Temp	Source Power
			
Valve Group	Manual Task	Input	Output

The manufacturer reserves the right to make design changes for product improvement. This manual may not reflect all details of these changes. Please contact Astro Packaging for further instructions.

Chapter 2

Description and Specifications

Description

The SS10 Hot Melt adhesive unit is designed with a constant speed direct drive motor/pump combination, and an adjustable output control. The melt unit consists of a heated melt tank and a motor-driven, positive displacement V4 series gear pump. The melt unit is compatible with a variety of Astro Packaging pattern controllers and head drivers.

This extremely reliable unit holds 10 lbs. of adhesive. The cylindrical teflon lined tank design virtually eliminates the possibility of char build up with an optional melt grid design to ensure consistent pump rates due to the flow through grid design.

The SS10 Hot Melt Unit is all-electric and accepts standard forms of adhesive. The unit is equipped with a flow control valve for fluid pressure and flow regulation. The melt unit has a 10 pound (4.54 kg) tank capacity, and supports 1 or 2 automatic or manual applicators and hoses.

All zone temperatures range from 4 °C (40 °F) to 232 °C (450 °F), adjustable by a TC500 Temperature Controller.

Electrical power to the melt unit is controlled by a power-disconnect circuit breaker located on the front end of the melt unit

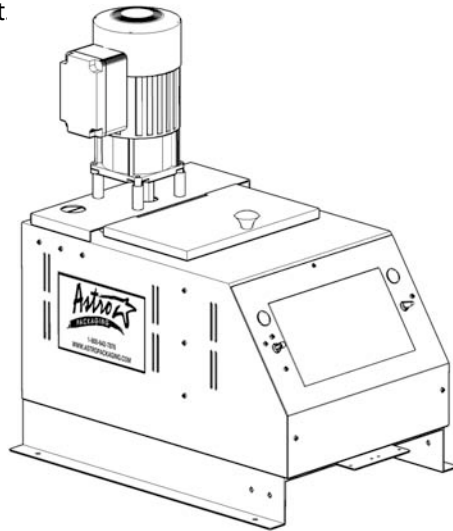

Features

- The solid-state Temperature Controller uses a Resistance Temperature Detector (PT 100 RTD) sensors to sample and regulate temperatures in the tank, hoses and applicators.
- Circuit breakers and fuses protect the entire system from overload.
- A tank-mounted over-temperature thermostat switch the system power off in the event of a tank controller failure.
- A circuit breaker protects the pump motor by switching the motor off should a stall or an overload condition occur.
- TC500 Temperature Controller protects pump/motor from starting before the material in system is Run-Ready.
- TC500 Temperature Controller provides a 7-Day Scheduler to Automatically turn the system On and Off once per day.
- TC500 Temperature Controller provides over-temperature protection to all zones and will shut down the main circuit breaker if tank over-temperature occurs.

Dimensions

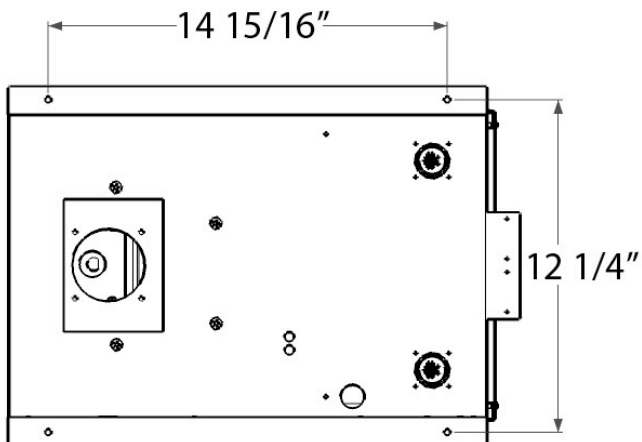
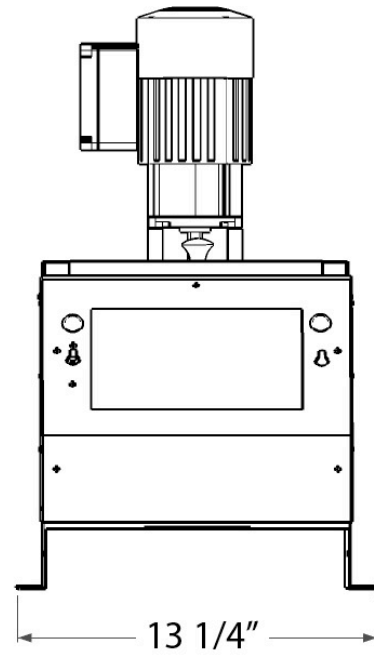
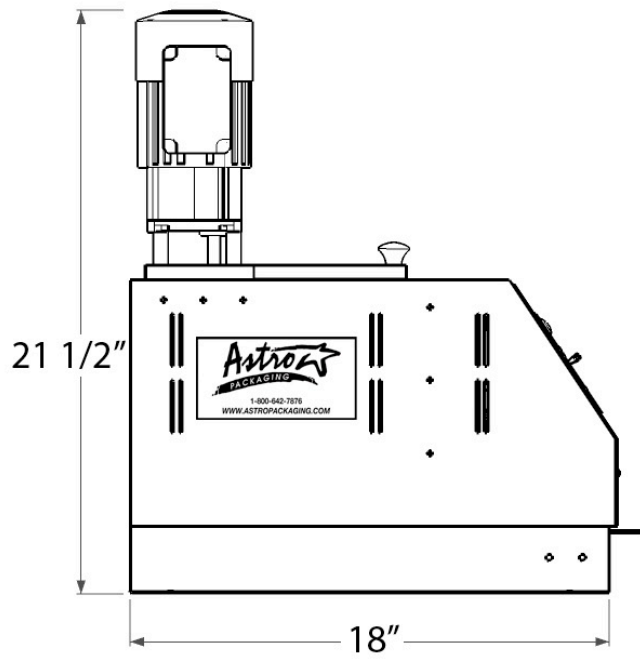
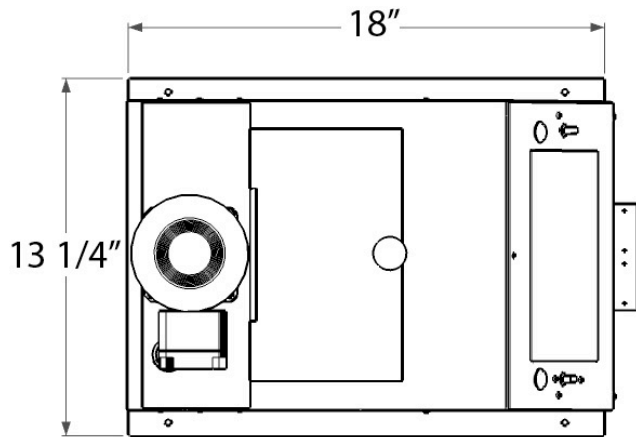

Chapter 3

Installation and Start-Up

Installation

Set-Up

1. Remove all packaging material from around the melt unit.
2. Carefully lift the melt unit out of the box.
3. Unpack the binder containing the product manuals, electrical schematics, and warranty information. Retain the binder for future reference.
4. Unscrew the 4 screws from the plywood board base; remove and discard the plywood.
5. Carefully inspect all packing material for separately wrapped items.
6. Position the melt unit for easy access to the control panel and convenient servicing.
7. Using the base mounting holes, bolt the melt unit down to a rigid mounting surface in accordance with the dimensions listed on pages 2-3 to prevent accidental upset and possible injury.
8. Tighten all screws before startup and after the melt unit experiences excessive vibration.

Component Installation

Automatic Systems

Hoses

Hoses are normally installed on an automatic melt unit at the factory with no user installation required. If they are not installed, see Hose Replacement. Refer to the enclosed Heated Supply Hoses product manual (Astro Packaging P/N 19600-24) for complete installation and service information.

Automatic Applicators

Automatic applicators may be attached to hoses or packaged separately. If they are not installed, proceed as follows:

1. With the system power off, attach the hose output electrical connector to the applicator. Heat the fluid fittings on the applicator and the output end of the hose by attaching the electrical connector and applying power for 3 – 5 minutes, or until the hose fitting will easily rotate.
2. Connect the output end of the hose to the adhesive input fitting on the applicator.
3. When the system reaches operating temperature, re-tighten all adhesive fittings. Pressurize and check for leaks.

Refer to the applicator product manual for installation and service information.

Gun Hanger

1. Open supplied bag containing: gun hanger and two 1/4-20 bolts.
2. While facing machine, on the right side; fasten bolts securely to base of the melt unit's chassis as shown in the illustration.

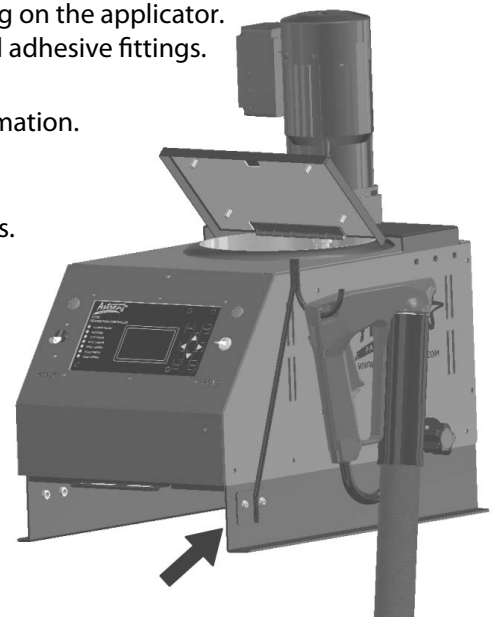

Electrical Circuits and Wiring

Power Requirements

The SS10 melt unit 120 VAC is wired for 2-wire, single-phase power, and comes with a power-cord with an 15 Amp plug. The 240 VAC unit comes with the power cord but the end user must supply the power plug for their power outlet. An identification plate is attached to each melt unit on the outside, rear panel of the tank housing.

This plate specifies the exact voltage of the melt unit, and the frequency of the pump motor. Pump motor voltage, frequency and current are specified on the motor data plate located on the motor housing. For safe and proper installation, refer to the identification plate before applying electrical power to the melt unit.

Electrical Connections

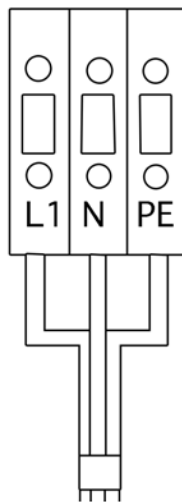

120 VAC L1/N
Single-phase service

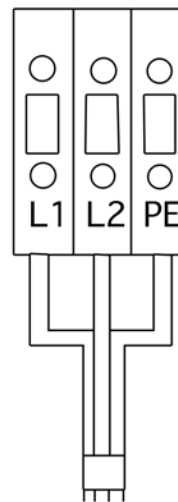

240 VAC L1, L2
Single-phase service

Operation



Start-Up

1. Become familiar with the temperature controller (TC500) information in the SS10 manual (See Chapter 4).
2. Install the melt unit.
3. Fill the tank with hot melt material up to 38 mm (1.5 in.) from the top.
4. Turn the unit on, and allow at least 30 minutes for the unit to properly warm-up.
5. Set the tank, hose, and applicator temperatures according to adhesive specifications. Lowering temperature settings will increase the material pot life.
6. Set the tank temperature as low as possible for each application. Certain materials degrade over time due to oxidation and can cause charring to occur.
7. **TO PREVENT STALLING THE MOTOR, ADJUST THE FLOW CONTROL VALVE COUNTERCLOCKWISE TO MINIMIZE PRESSURE AND LOWER FLOW RATE.**

***NOTE: the pump motor will not run until the TC500 has green ready LED, and the handgun trigger is squeezed. For automatic guns, cable part number: 73140-45 is required.**

Adding Adhesive



WARNING HOT ADHESIVE

Do not overfill the melt tank since adhesive generally expands as it melts and a full tank may overflow.



CAUTION: Using adhesive with viscosity over 50,000 centipoise may cause the pump to stall.

The adhesive level should be maintained at 13 mm to 100 mm (1/2" to 4") from the top of the tank. Where applications demand a high output volume of adhesive, add small amounts of adhesive frequently. ADDING LARGE AMOUNTS OF ADHESIVE TO AN ALMOST EMPTY TANK WILL LOWER THE TEMPERATURE AND MAY CAUSE THE MELT UNIT TO FALL BELOW ITS READY SET-POINT.

Changing the Adhesive Formula

If a different adhesive formulation from the one being currently used is needed, the system will have to be flushed if the two formulations are incompatible. See Chapter 6 of this manual for the proper flushing procedure. When in doubt about adhesive compatibility, flush your system.

Flow Adjustments



WARNING:

Contents at high temperature and pressure. Remove pressure before opening filter or drain valve to prevent accidental system pressurization or firing. Do not touch hot surfaces. Failure to follow these instructions may result in severe burns.



CAUTION:

For maximum performance and motor life, do not allow the pump motor to stall. A prolonged stall condition will cause the motor to go into thermal overload.

Flow Control Valve

An adjustable, pressure-regulating device is mounted on the pump under the melt unit chassis. See the illustration below.

- Adjust the flow control by turning the black knob on the right side of the melt unit.
- To **increase** the pressure, turn **clockwise**.
- To **decrease** the pressure, turn **counterclockwise**.
- To achieve the minimum pressure and the lowest flow rate, turn the knob fully counterclockwise. **SLOWLY** turn clockwise until the desired pressure and flow rate are achieved.

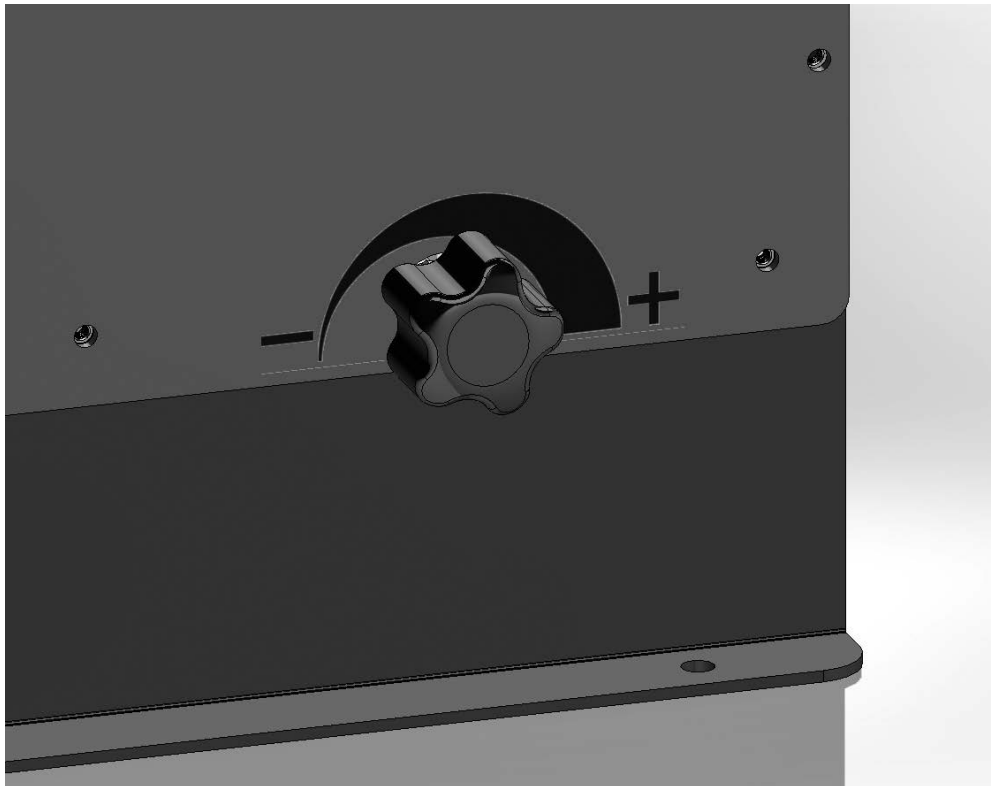

Gun Hanger Installation

Storage and Disposal of the SS10 Application System

Temporary Storage of the Unit

1. Flush the adhesive application system with flushing fluid (P/N: RB-5), following the instructions detailed in Chapter 5 (Page 5-2) of this manual.
2. Shut OFF all pressure and power sources.
3. Remove all residual adhesive and wipe components clean.
4. Disconnect all power supply cables.
5. Pack the unit in a corrosion-proof container.
6. Store the unit in such a way that it is protected from damage.

Disposal of the Unit

1. **Shut OFF** all pneumatic and power sources.
2. Remove all residual adhesive.
3. Remove all adhesive supply hoses and all power supply cables.
4. Dismantle all components and sort into mechanical and electrical components.
5. Arrange for all components to be recycled.

Chapter 4

TC 500 Temperature Controller

L1 Software

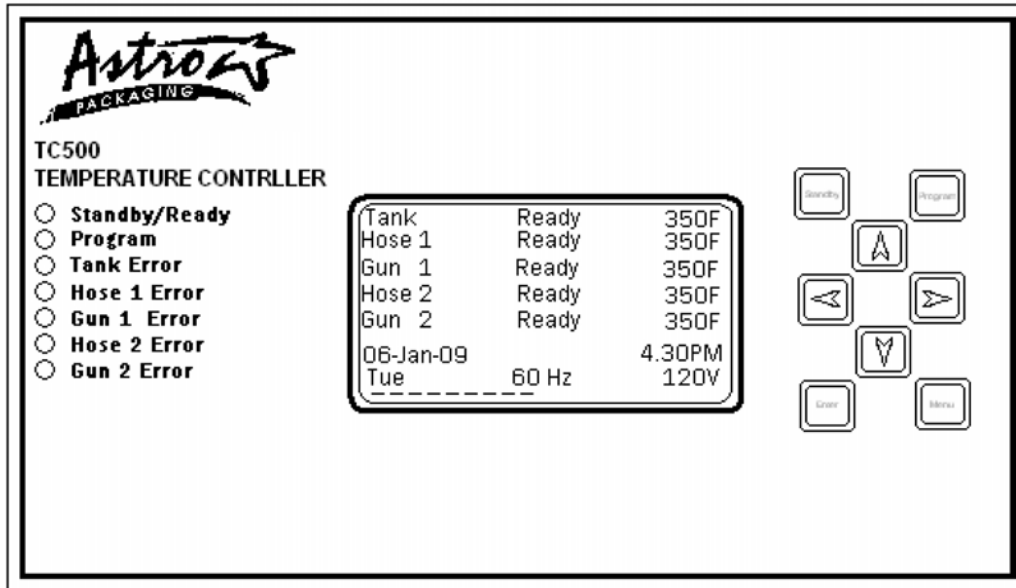

PRELIMINARY (revision K1)

The TC500 Temperature Controller revision "L1" includes a non-adjustable built-in **SEQUENTIAL START-UP**; the tank, hoses and guns heat up in sequence. First the tank, followed by the hoses and then the guns.

Programming Temperature Set-Points

Press and release the following sequence:
Program, Menu (1X), Enter



Press and release the Menu button until the desired Menu is displayed.

To choose between the following parameters press the left or right arrows.

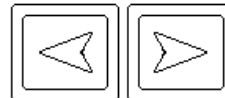

Tank
Tank Ready Delay (1-60 minutes)
Hose 1
Gun 1
Hose 2
Gun 2

To increase or decrease values press Up or Down arrows



To exit press Program



Set Offset Temperatures

Press and release the following sequence:
Program, Menu (2X), Enter



Press and release the Menu button until the desired Menu is displayed.

To choose between the following parameters press the left or right arrows.

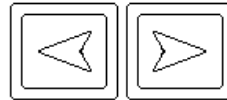

Motor Cut Off

Tank

Hose1

Gun 1

Hose2

Gun 2

Standby

Tank

Hose1

Gun 1

Hose2

Gun 2

Over temp

Tank

Hose1

Gun 1

Hose2

Gun 2

To increase or decrease values press the Up or Down arrows



To exit press Program



Set Automatic Wakeup

Press and release the following sequence:
Program, Menu (3X), Enter



Press and release the Menu button until the desired Menu is displayed.

After setting automatic wakeup, perform Various System Tasks on page 4-7, and turn ON the "Automatic ON/OFF 7 day clock timer"

To choose between the following parameters press the left or right arrows.

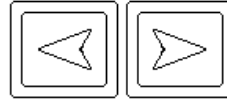

Next/Previous (1-14) -->

Day

Hour

Minute

On/Off Event # 1 & 2 Sunday

Event # 3 & 4 Monday

Event # 5 & 6 Tuesday

Event # 7 & 8 Wednesday

Event # 9 & 10 Thursday

Event # 11 & 12 Friday

Event # 13 & 14 Saturday

Note that Event #1 must start on Sunday

To increase or decrease values press the Up or Down arrows

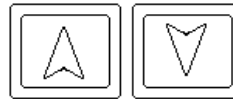

To exit press Program



Set Clock Calendar

Press and release the following sequence:
Program, Menu (4X), Enter



Press and release the Menu button until the desired Menu is displayed.

To choose between the following parameters press the left or right arrows.

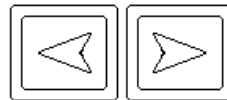

Year

Month

Date

Day

Hours

Minutes

To increase or decrease values press the Up or Down arrows



To exit press Program



Save and Register Settings

Press and release the following sequence:
Program, Menu (5X), Enter



Press and release the Menu button until the desired Menu is displayed.

To choose between the following parameters press the left or right arrows.



Save Operating Variables as backup
Load Operating Variables from Back Up
Load Operating Variables from Factory Settings

To increase or decrease values press Up or Down arrows



To exit press Program



Display/Set Audit Variables

Press and release the following sequence:
Program, Menu (6X), Enter



Press and release the Menu button until the desired Menu is displayed.

This menu is for viewing only, it can't be altered.

To choose between the following parameters press the left or right arrows.

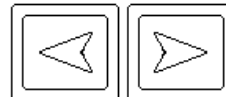

System run time counter
Years = 0000
Days = 0000
Hours = 0000
Software Revision
K1 and the date it was revised (20-MAR-2010).
To exit press Program



Performance Various Maintenance Tasks

Press and release the following sequence:
Program, Menu (7X), Enter



Press and release the Menu button until the desired Menu is displayed.

To choose between the following parameters press the left or right arrows.



System Calibration Tank xxx.xx Ω
System Calibration Spare xxx.xx Ω
System Calibration Hose 1 xxx.xx Ω
System Calibration Gun 1 xxx.xx Ω
System Calibration Hose 2 xxx.xx Ω
System Calibration Gun 2 xxx.xx Ω
System Calibration 110 Ohms
System Calibration 240 Ohms
System Calibration Frequency 60 Hz
System Calibration Voltage xxx.x V

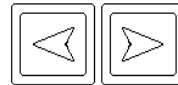

Test LED Lamps

(LED Test, Run Now)

- Standby/Ready
- Tank
- Hose 1
- Gun 1
- Hose 2

Gun 2



Performance Various Maintenance Tasks Continued

Press and release the following sequence:
Program, Menu (7X), Enter



Press and release the Menu button until the desired Menu is displayed.

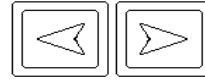

LCD Back Light Intensity
Current Level xxx %

Change Level 1.9-100%



To increase or decrease values press Up or Down arrows



To exit press Program



Performance Various System Tasks

Press and release the following sequence:
Program, Menu (8X), Enter



Press and release the Menu button until the desired Menu is displayed.

To choose between the following parameters press the left or right arrows.

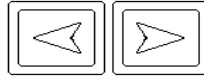

Toggle Display Temperatures between C/F
C to F/ F to C

Set Line Voltage

120V
240V
Auto 120V
Auto 240V

Set Line Frequency

50 Hz
60 Hz
Auto 50 Hz
Auto 60 Hz

Power Set Mode

1-7

7 is recommended

Disable hose 1

Currently On/Off

Disable Gun 1

Currently On/Off

Disable hose 2

Currently On/Off

Disable Gun 2

Currently On/Off

Trigger 1 Safety enable

Currently On/Off

Trigger 2 Safety enable

Currently On/Off

(ON for handguns)

Automatic On/Off, 7 day clock timer

On/Off

Security Lock Level

Off – 1 – 2 – 3 (see next sheet)

Level 3 is recommended

To change values press the Up or Down arrows



To exit press Program



SECURITY LOCK LEVEL

Level 1: Some restrictions but not all

Level 2: Some menus can be modified until a power cycle or reset.

Level 3: Most restrictive

Parameter	OFF	LEVEL 1	LEVEL 2	LEVEL 3
Programming Temperature Setpoints	Unlock	Lock	Unlock	Not visible
Offset Temperatures	Unlock	Lock	Unlock	Not visible
Automatic Wakeup	Unlock	Unlock	Unlock	Not visible
Set Clock Calendar	Unlock	Unlock	Unlock	Not visible
Save and Register Settings	N/A	N/A	N/A	Not visible
Display/Set Audit Variables	N/A	N/A	N/A	N/A
Performance Various System Tasks	Unlock	Unlock	Unlock	Unlock

Record your settings on this sheet

PARAMETER	CHANNEL	TEMPS	NOTES
Set Temperatures	Tank		
	Hose 1		
	Gun 1		
	Hose 2		
	Gun 2		
Set Offset Temperatures			
Motor Cut Off	Tank		
	Hose 1		
	Gun 1		
	Hose 2		
	Gun 2		
Standby	Tank		
	Hose 1		
	Gun 1		
	Hose 2		
	Gun 2		
Over temperature	Tank		
	Hose 1		
	Gun 1		
	Hose 2		
	Gun 2		

Set Automatic Wakeup
Note that Event #1 must start on Sunday

Event	Day	Hour	Minute	On/Off	Notes
#1	Sunday				
#2	Sunday				
#3	Monday				
#4	Monday				
#5	Tuesday				
#6	Tuesday				
#7	Wednesday				
#8	Wednesday				
#9	Thursday				
#10	Thursday				
#11	Friday				
#12	Friday				
#13	Saturday				
#14	Saturday				



Performance Various System Tasks

	Notes
Toggle Display Temperatures between C/F	
Set Line Voltage	
Set Line Frequency	
Power Set Mode	7 is recommended
Disable hose and gun 1	
Disable hose and gun 2	
Trigger Safety Enable	ON for handguns
Automatic On/Off, 7 Day clock Timer	
Security Lock Level	1 is recommended

Chapter 5

Preventive Maintenance

Maintenance

	<p style="text-align: center;">WARNING:</p> <p>Hot melt materials can cause severe burns resulting in disfigurement or blindness. Follow these precautions before beginning any maintenance:</p> <ul style="list-style-type: none"> • Wear protective clothing, safety goggles, and safety gloves. • Turn pump motor switch to the off position. • Depressurize applicator(s) by triggering. • Unless stated otherwise, always allow melt unit to cool before beginning any maintenance. • Disconnect hose electrical connector when hose fittings are disconnected and power is off.
	<p style="text-align: center;">CAUTION:</p> <p>To prevent damage to components (hose fittings, etc.), heat part(s) being serviced to approximately 121 °C (250°F) prior to dismantling, assembling, or adjusting. Heat parts by applying power to the unit using a hand held hot air gun or placing parts on a hot plate. Failure to do this will result in stripped threads and ruining both parts and tools.</p>
	<p style="text-align: center;">CAUTION:</p> <p>To avoid arcing of electrical contacts and possible failure of components, do not connect electrical connectors when the hose power switch is on.</p>

Preventive Maintenance

Procedure	Daily	Monthly	As Required
Check for foreign material in tank	X		
Wipe off excess hot melt from cover.	X		
Check for leaks.	X		
Purge tank and hose(s).		X	X
Inspect hose(s). Verify hose(s) properly supported. Minimum bend radius is 20.32 cm (8 in.) when hot.		X	
Check temperatures. Adjust temperatures according to Temperature Controller manual.		X	
Clear applicator nozzles.			X

Flushing the Hot Melt Unit

Flushing the Hot Melt Unit with P8200 Cleaning Compound

P8200 is an organic, non-hazardous, non-corrosive FDA approved cleaning material specially formulated for cleaning hot melt application equipment. It may be used with EVA, Polyolefin, Acrylic, Polyamide and rubber based adhesives for:

- Routine Maintenance and Cleaning
- Purging charred and degraded adhesives
- Changing out adhesives
- Helping maintain good equipment operations, including preventing nozzle clogging, hose constrictions and poor pump stroke.

Using P8200 or an equivalent cleaning solution on a routine basis, will help reduce degradation in difficult to clean places, improve heat transfer efficiency throughout the system, and result in overall longer equipment life. P8200 may also be used also to clean nozzles and filters separately.

Use P8200:

- When filters show evidence of charring
- When nozzles begin to plug or poor cutoff/stringing effect.
- When changing adhesives
- During routine cleanups and shut downs

Recommended Clean-out Procedure:



Safety Precautions should be observed. We recommend using safety glasses and gloves when working around hot melt systems.

1. Drain system of all adhesive and fill with P8200.
2. Heat system to normal operating temperature (300 to 375° F). **DO NOT EXCEED RECOMMENDED TEMPERATURES.** Additional heating will not improve the cleaning performance.
3. When operating temperature is reached, begin re-circulating the system until the reservoir is clean and char is broken down.
4. After sufficient re-circulation, reduce pump pressure, empty the contents of the reservoir into a safe container. While the components of P8200 are not toxic, some of the materials removed may be.
5. Once the system is drained, remove any remaining char with non-metal tools so as not to scratch the teflon-coated tank using the appropriate tools.
6. Add new adhesive, and discard the first few minutes of adhesive output, resume production.



AVOID OPEN FLAMES WHEN OPERATING. DO NOT EXCEED THE RECOMMENDED TEMPERATURES. reservoir covered when in use to minimize odor. USE IN A WELL VENTILATED AREA.

Chapter 6 Troubleshooting

Problem	Solutions
Unit does not power up (no power light).	<ol style="list-style-type: none"> 1. Verify that there is power in and out of the main circuit breaker. Refer to wiring schematic. 2. Check supply voltage to melt unit with voltmeter. The voltage of each component must equal the supply voltage or system damage may occur.
Temperature Control board does not power up.	<ol style="list-style-type: none"> 1. Check power to unit. 2. If power light by main breaker is on, check power to LED on power board. Replace power board if the LED is not on. 3. Check ribbon cable connections if power LED is on.
Tank does not heat.	<ol style="list-style-type: none"> 1. Check 8 Amp tank fuses on power board. (F1, F2) 2. Check the temperature controller for Power On and Tank Temperature Set. Refer to Chapter 4: TC500 Temperature Controller Guide. 3. Inspect the power connections for proper fit. 4. Check for any faulty wires. 5. Check the supply voltage, or system damage will occur. 6. If problem still exists, check each heater with an amperage probe (system powered on) or an ohmmeter (system powered off, wires disconnected). Refer to the schematics in Ch. 9.
Tank heats slowly.	<ol style="list-style-type: none"> 1. Check 8 Amp tank fuses on power board (F1 & F2). 2. Check the status of components with a voltmeter (system powered) or an ohmmeter (system powered down, wires disconnected). 3. Adjust the tank temperature. Inadequate tank heat can affect overall performance. 4. If problem still exists, replace tank heaters as specified under tank heater replacement section on page 7-3.
Zone over-temperature.	<ol style="list-style-type: none"> 1. Check the zone temperature when an over-temp condition is present. The tank over-temp switch shuts down the main breaker if the tank reaches 450°F.

Problem	Solutions
Applicator and hose heat slowly, low voltage.	1. Adjust the hose and applicator settings. Verify power mode on TC500 is set to 7.
Motor does not turn.	<ol style="list-style-type: none"> 1. Check to see if applicator or hose is programmed on the TC500. See TC500 manual. 2. Check to see if the green ready light on the TC500 is ON. 3. If handgun is used verify switch in gun is closing. 4. Check to see if pump circuit breaker switch is On. 5. Check to verify there is no obstruction in pump. 6. Check 5 Amp motor fuse on power board (F3). 7. Decrease flow control setting (turning counter-clockwise).
Applicator and hose fail to heat.	<ol style="list-style-type: none"> 1. Check 6.3 Amp fuse on power board (F4, F5). 2. Check to see that the proper zone(s) are enabled on the TC500 temperature controller. 3. If there is no change, disconnect the hose electrical connection, and check the hose and gun heater resistance value with an ohmmeter. NOTE: The hose heater is pin 2 and 6 of the 16 pin connector, the gun heater is pin 2 and 3. If the heater is open- replace heater (at 16 pin male connectors of the hose). 4. Determine if the applicator is heating by using a pyrometer or thermometer or similar device. <u>Do not touch applicator by hand to determine temperature.</u>
Adhesive output is too high.	<ol style="list-style-type: none"> 1. Decrease the fluid pressure with the flow control valve (3-4). If there is no change, remove the nozzle and replace it with a smaller orifice nozzle. 2. Decrease the hose temperature by 4-10°C (25-50°F). If there is no change, consult Astro Packaging regarding application.

Problem	Solutions
Adhesive output is too low.	<ol style="list-style-type: none"> 1. Increase the system fluid pressure, taking great care not to stall the motor, by adjusting the flow control valve. If there is no change, remove the nozzle and replace it with a larger-orifice nozzle. 2. Clean applicator nozzle. 3. Clean/replace gun filter. 4. Check to be sure that the system temperatures are correct for adhesive being dispensed. 5. Increase the hose temperature by 4-10°C (25-50°F). If there is no change, consult Astro Packaging regarding the application.

Contact Astro Packaging Technical Services department for assistance at (800) 642-7876

Chapter 7

Repair & Replacement

- Refer to Parts List, in Chapter 8, for all replacement parts listed in this section.

Hose Replacement



CAUTION:
For safe and proper hose replacement, verify that all material in melt tank has completely solidified.

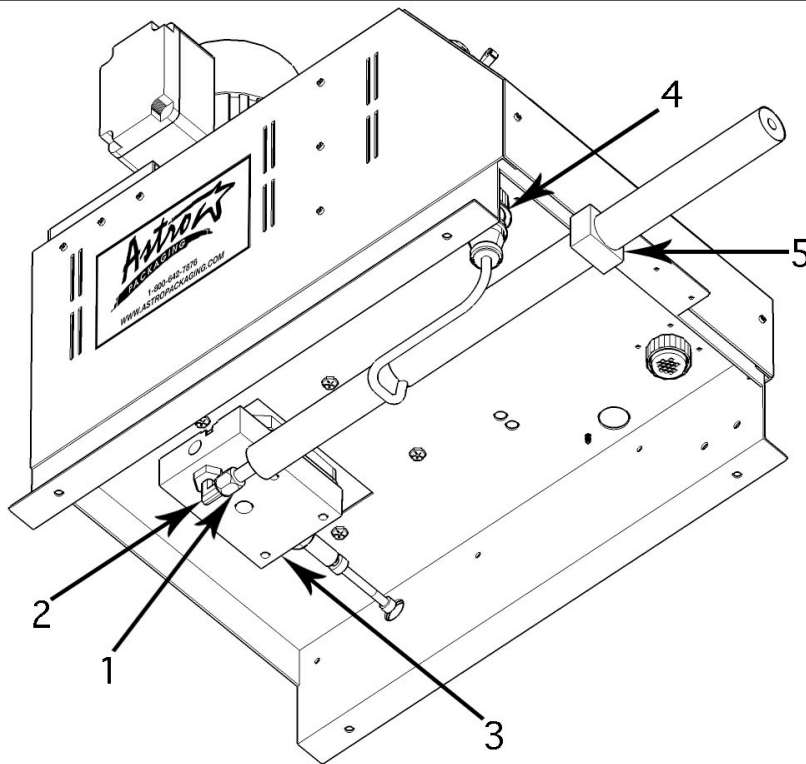

3-18-11



CAUTION:
The illustration above is for reference only. **DO NOT TURN THE MELT UNIT UPSIDE DOWN.** Failure to comply with this caution can result in injury and/or damage to the equipment.

Removal of an Existing Hose

1. Switch the system power off, and be sure ALL fluid pressure has been discharged before
2. If system is cold, switch the system on for 10 minutes to allow the fittings to warm, or heat the fitting with a hand-held hot air gun.
3. Switch the system power off, and disconnect the melt unit electrical power from the external source.
4. Disconnect the hose electrical connector [4].
5. Remove the screws from the hose-mounting block [5].
6. Loosen the hose JIC fitting [1], and remove the hose from the fitting [2] on the flow control block [3].

Installation of a New Hose

1. Never flex a hose when it is cold. Hoses have a minimum bend radius of 20.32 cm (8 in.) when hot. Further flexing will cause permanent damage.
2. Switch off the system power, and disconnect the melt unit electrical power from the external source.
3. Heat the hose JIC fittings [1] before adjusting, or damage may result. New or clean hose fittings may not require heating.
4. Install the hoses onto the melt unit by tilting the unit back until the underside is accessible.
5. Support the melt unit with a block on the back of the housing so that hot melt does not spill. Do not turn the melt unit upside down.
6. Support the hose to prevent excessive flexing. Do not support the hose in a way which may add to its thermal insulating characteristics, or overheating will result. Failure to properly support the hose will result in premature failure.

Install the hose as follows:

1. Loosely connect the hose JIC swivel fitting [1] to the fitting [2] on the flow control block or hose manifold [3].
2. Fasten the hose support block [5] to the chassis.
3. Tighten the JIC swivel fitting [1].
4. Attach the hose electrical connector [4]
5. Fasten the hose electrical connector [4] under the melt unit using provided Astro velcro strap.
6. Position and support the hose for proper fluid flow before using.
7. After heating the hose, tighten the JIC swivel fitting [1].

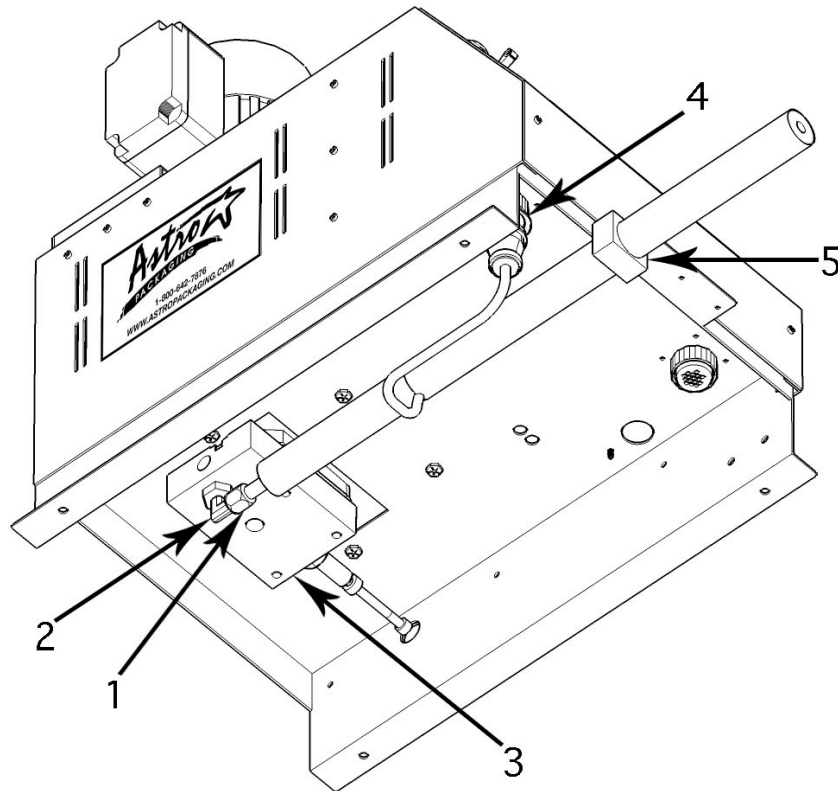

3-18-11

Tank Heater Replacement

1. Switch off the system power, and disconnect electrical power from external source.
2. Open front door to access power board.
3. Disconnect heater(s) from power board (J6 & J7).
4. Remove electrical panel access cover to access heater(s) located at the tank base.
5. Pull the heater out of its bore. If heater does not come out easily, drive it out using a 6.35 mm (.25 in.) diameter rod inserted into the knockout holes in the back of the tank base. To access knockout holes, remove back door.
6. Once existing heaters have been removed, apply a coating of thermal paste (Dow Corning 340 or equivalent, P/N:30122-3) to new heater(s) and slide it into the tank heater bore from the front of the tank.
7. Reroute heater wires through the electrical panel and reconnect heater wires to power board.
8. Reinstall electrical panel access cover, front door, and back door if it was removed.
9. Reconnect power to external source and return to service.

NOTE: The tank heater connections at the power board are J6 and J7, and are fused by F1 and F2.

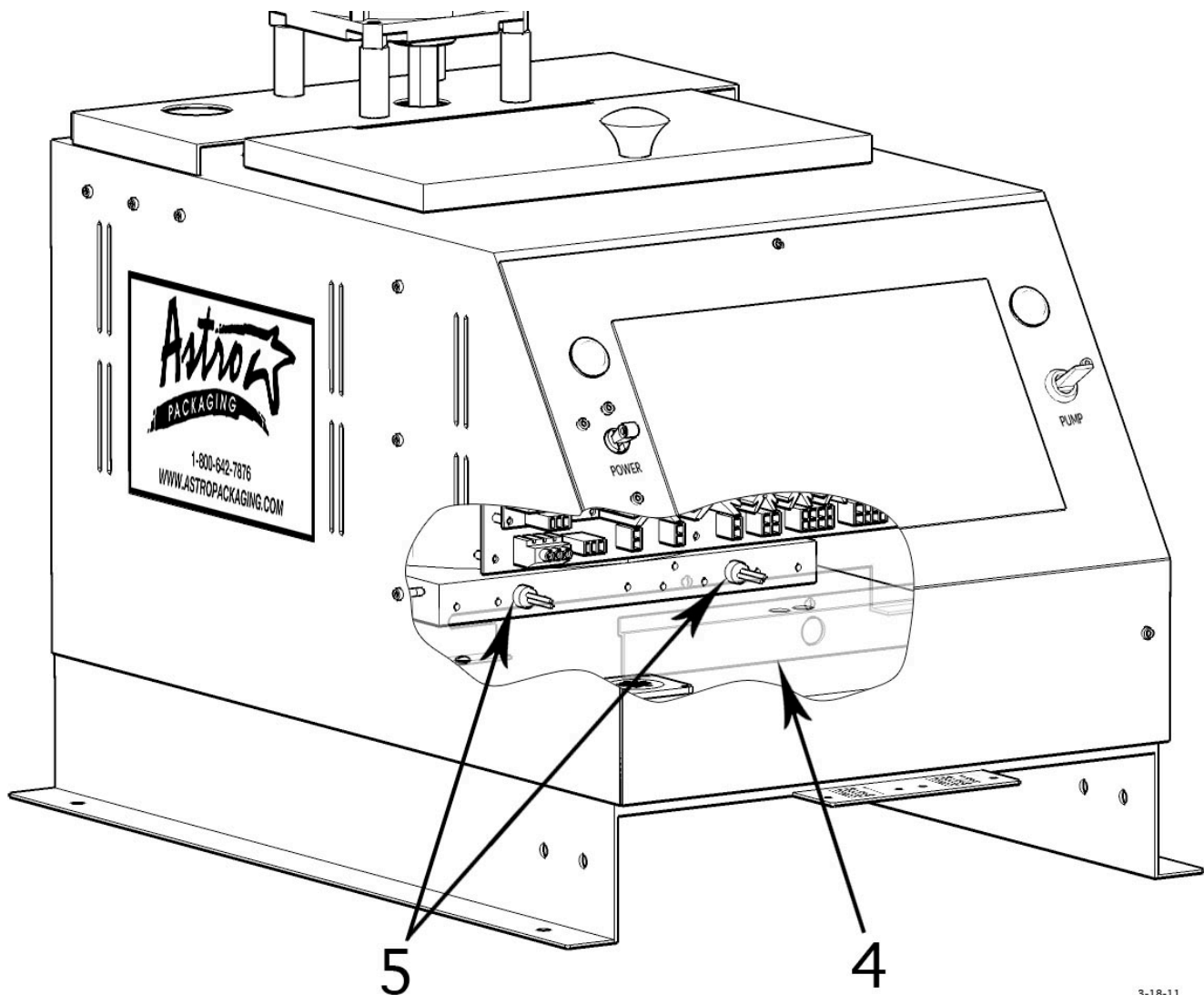

3-18-11

Tank RTD Sensor Replacement

1. Switch off the system power, and disconnect electrical power from external source.
2. Open front door to access power board.
3. Disconnect RTD sensor from power board at J2.
4. Remove electrical panel access cover to access RTD sensor located in the middle of the tank base.
5. Pull RTD sensor out of its bore.
6. Once existing RTD sensor has been removed, apply a coating of heat release to the new RTD sensor and slide it back into the RTD sensor bore.
7. Reroute RTD sensor wire back to power board and reconnect.
NOTE: The RTD sensor plugs into the power board at J2.
8. Reinstall electrical panel access cover and close front door.
9. Reconnect power to external source and return to service.

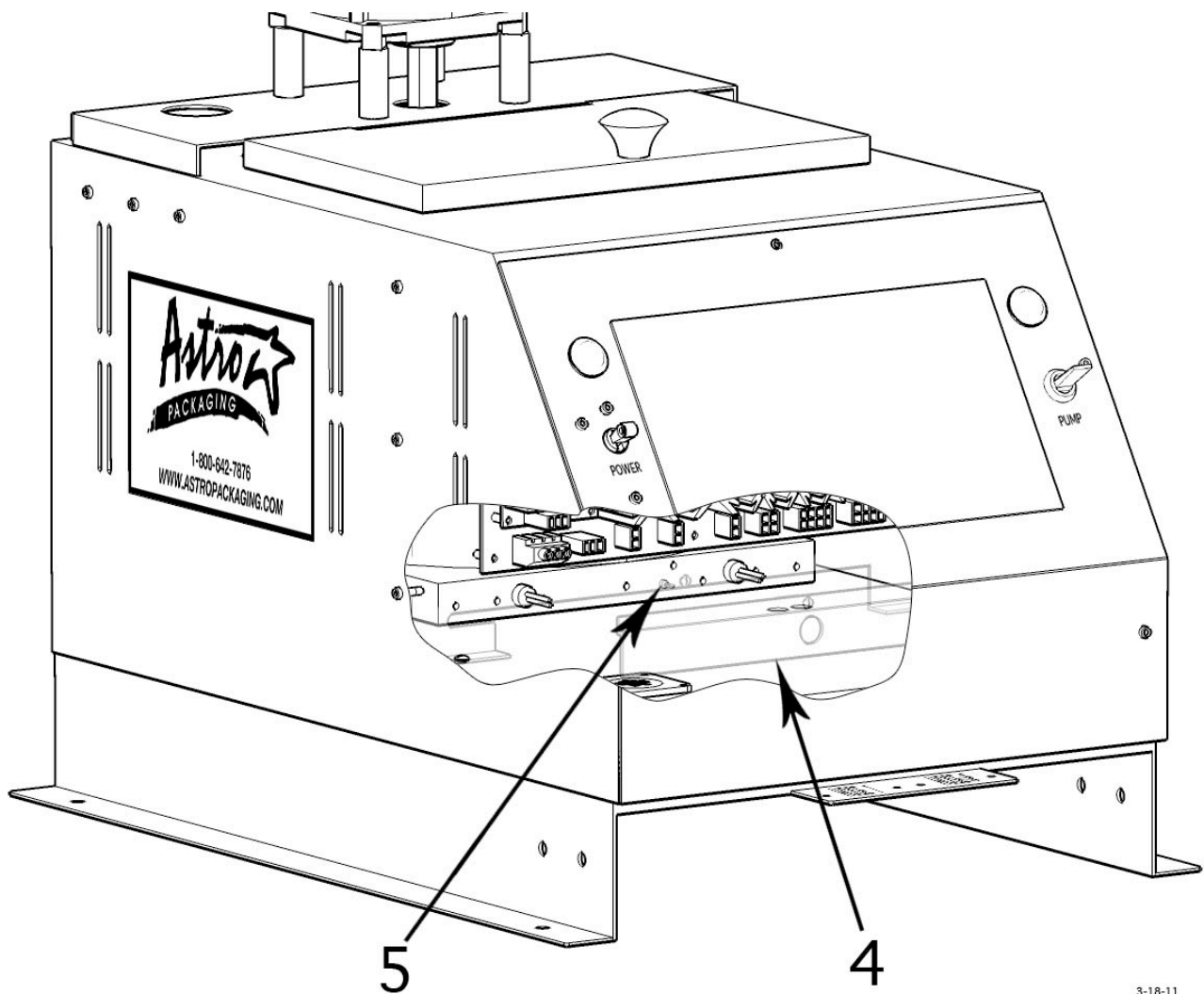

3-18-11

Tank Over-temperature Thermostat Replacement



WARNING:

The over-temperature thermostat is necessary device for preventing runaway heating on all melt units, do not bypass this protection. Runaway heating of the tank can result in combustion of adhesive and will destroy unit and void all warranties.

1. Switch off the system power, and disconnect electrical power from external source.
2. Open front door to access power board.
3. Disconnect Tank Over-Temperature Thermostat from power board.
NOTE: The Tank Over-Temperature Thermostat plugs into J8 on the power board.
4. Remove electrical panel access cover to allow removal of Tank Over-Temperature Thermostat.
5. To access Tank Over-Temperature Thermostat, remove the back door.
6. Remove two screws holding the Tank Over-Temperature Thermostat to the back of the tank base.
7. Once existing Tank Over-Temperature Thermostat has been removed, wipe off existing thermal paste with a rag and apply a coating of thermal paste (Dow Corning 340 or equivalent) to new Tank Over-Temperature Thermostat.
8. Fasten the Tank Over-Temperature Thermostat to the tank base with the two screws provided and reroute the wires back to the power board.
NOTE: The Tank Over-Temperature Thermostat plugs into J8 on the power board.
9. Reinstall electrical panel access cover, front door, and back door.
10. Reconnect power to external source and return to service.

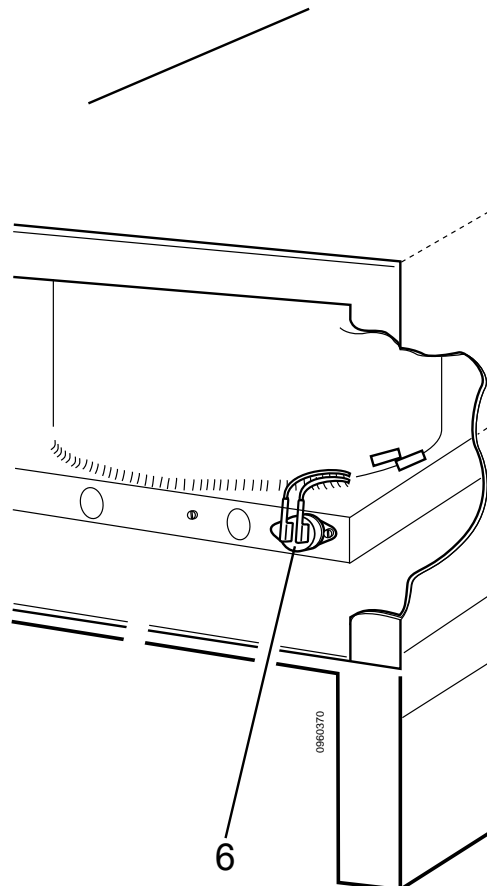

Flow Control Block Replacement

1. If possible, pump out all adhesive in the melt unit before disconnecting power. If not possible, disconnect power and allow hot melt in tank to solidify.
2. Switch on power for 5 minutes to warm fittings.
3. Switch off system power and disconnect electrical power at external source.
4. Disconnect hose electrical connectors and tilt melt unit backwards. Support the melt unit with block on back of housing so hot melt does not spill. Do not turn melt unit upside down.
5. Per illustration below, loosen JIC fittings [5] and remove hose(s) from fitting(s) [6] on flow control block [3].
6. Remove screws [4] from flow control block [3].
7. Install view flow control block.
8. Switch on system power, allow melt unit to reach operating temperature.
9. Reconnect hoses as specified in Hose Replacement (7-2).

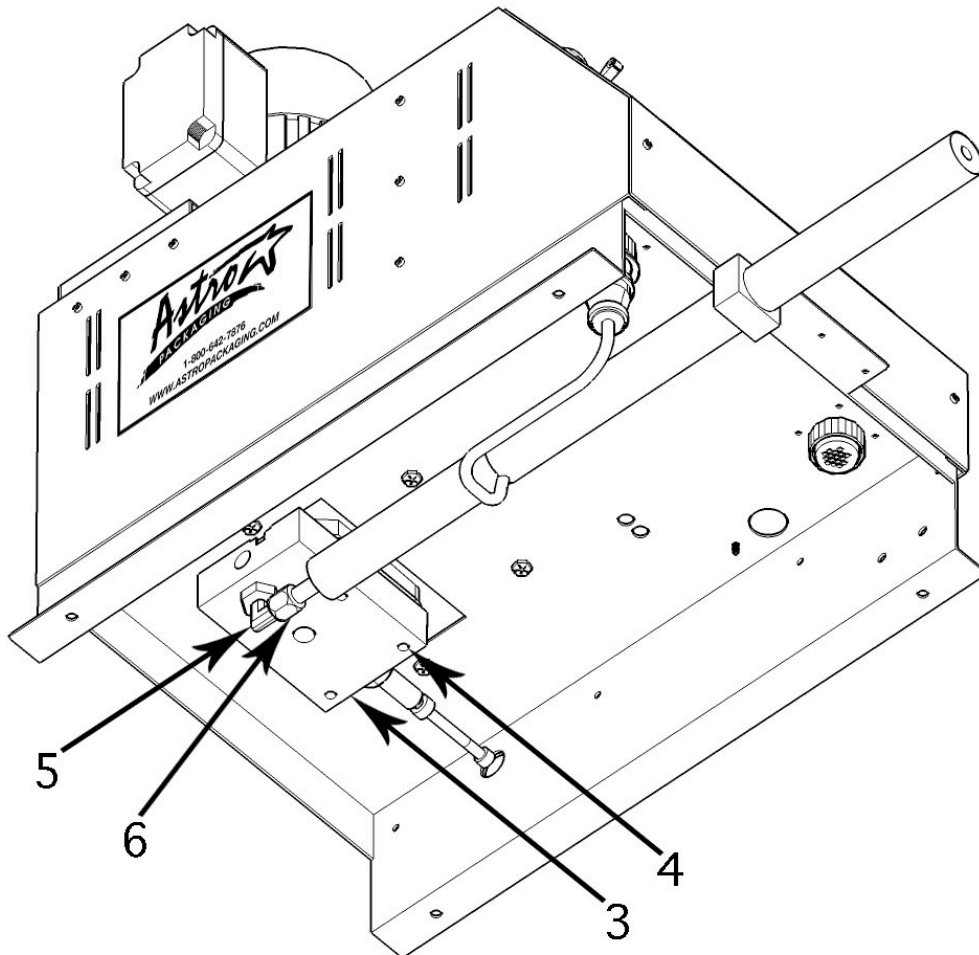

3-18-11

Pump Motor and Pump Shaft Assembly Replacement

1. Disconnect electrical power and allow melt unit to cool to a minimum of 121°C (250°F).
2. Per illustration below, open motor junction box cover [1], disconnect wiring and liquatite fitting.
3. Remove screws [4] holding motor mounting plate to melt unit.
4. Lift motor assembly off melt unit.
5. Inspect motor shaft coupler [3] for wear. Replace if necessary.
6. Install new shaft assembly or individual components as needed.
7. Remove screws [5] holding pump motor to motor mounting plate [6].
8. Install new pump motor on motor mounting plate.
9. Check pump shaft alignment on pump in tank and allow for vertical shaft movement.
10. Align motor coupling [3] with pump shaft in tank and lower onto shaft.
11. Align motor mounting plate to melt unit with mounting screws [4].
12. Replace liquatite fitting and wires [2].
13. Reconnect wires according to electrical schematic. Refer to melt unit identification plate to determine exact voltage.
14. Turn on melt unit and allow melt unit to heat to normal operating temperature. Turn on pump motor.
15. Tighten screws [4] in a crisscross pattern while in motor is operating to align pump shaft.
16. Once tightened ,pump shaft should not be under compression/tension and she be able to move freely up and and down and have vertical play.

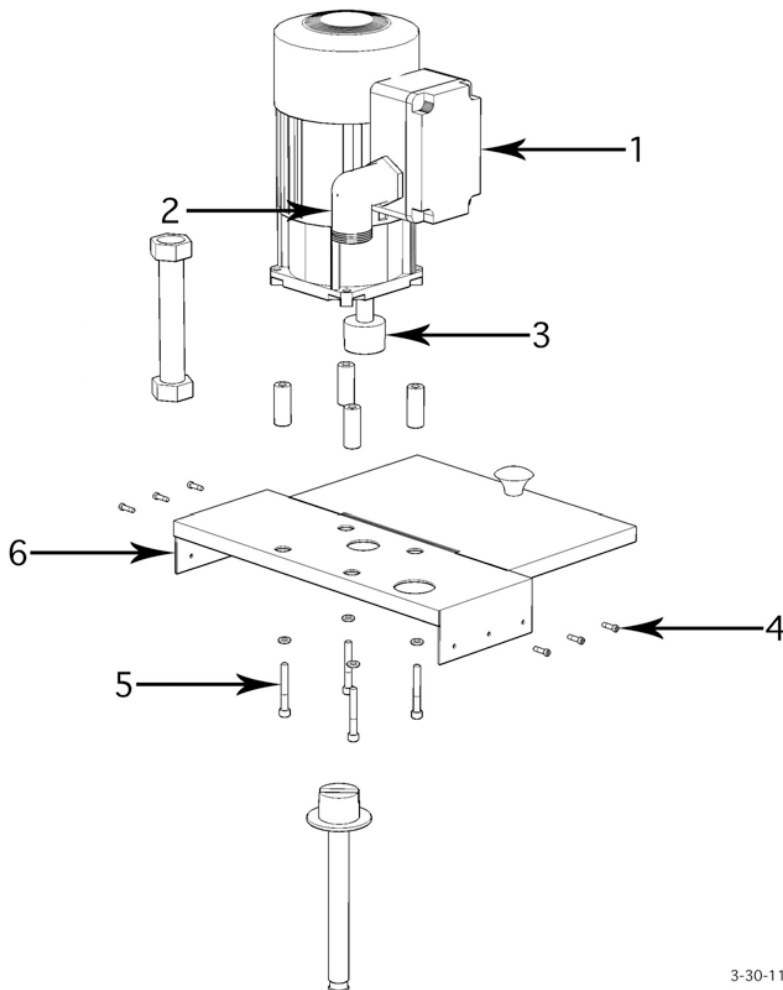

Chapter 8

Component Illustration and Bill of Materials

Recommended Spare Parts

Part Number	Description	Qty
12014-8B	Fuse, 8 amp, 5 X 20mm, 240V	2
12014-5B	Fuse, 5 amp, 5 X 20mm	2
939683	Fuse, 6.3 amp, 5 X 20mm, Fast Acting	2
D200109	Tank RTD, 100 ohm	1
D200111	Over-temp Thermostat, 475°	1

Optional Accessories

Part Number	Description	Qty
79033-1	Melt Grid	1
79282-01	Kit, Tank Screen (only to be used with 79033-1)	1
70201-2	Rear Entry Hose Support Bracket	1
DSC2436	Deck Style Cart	1
99786	Hose Boom & Balancer Assembly	1
99786-A	Base	1
99786-B	Boom (3 pieces)	1
99786-C	Hammock with Hardware	1
99786-E	Locking Collar	1
RF-8	Hose Retractor	1
79281-01	Hose Mole Kit (see page 5-3)	1
79353-24	Kit, Swirl Spray Air	1
79302-03	Kit, Down Apply Swirl	1

Tank Components

Item	Description	Part Number	Qty
1	Over-temperature Thermostat, 232°C (475°F)	D200111	1
2	Sensor, RTD, 100 ohm, Tank	D200109	1
3	Tank Heater, 120 V, 400 W	12532	2
3	Tank Heater, 240 V, 400 W	12538	2
4	Tank Seal, 29 Inch.	70020-29	1
5	Motor Mount and Outer Lid	70586-LS10-4	1
6	SS10 Tank Assembly	73010-2	1
7	Tank Screen	70030	1
	Knob	14517-14	1
	Lid, Inner,	70586-IS10-6	1
8	Optional Kit, Melt Grid w/ Screws	79033-1	1
9	Optional Kit, Tank Screen	79282-01	1

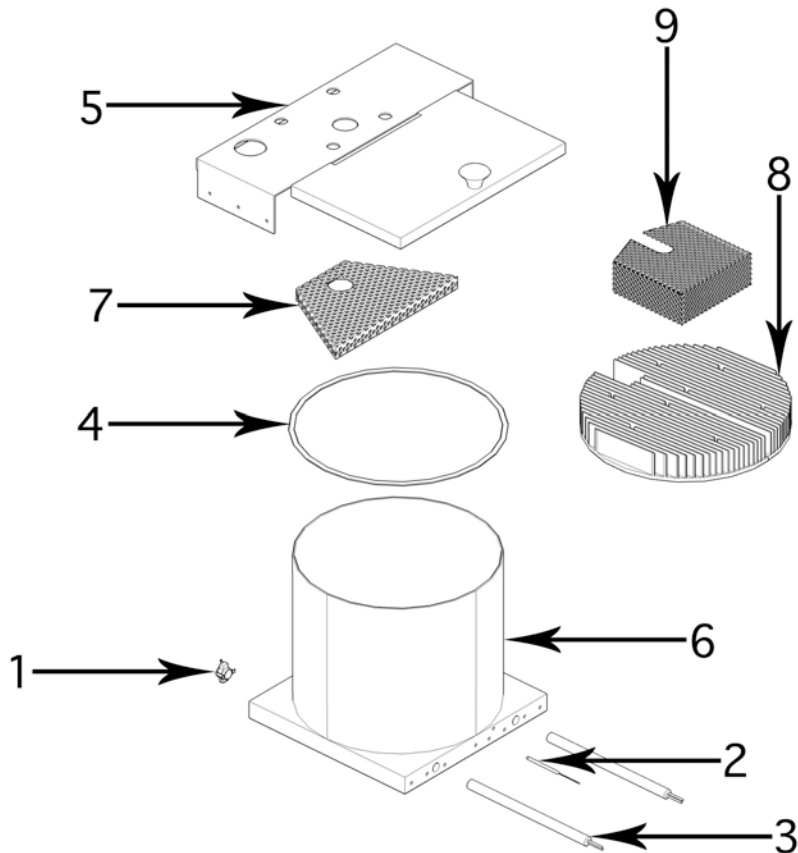

3-9-11

**** This Page is Intentionally left blank. ****

Motor Group and Mounting Hardware

Item	Description	Part Number	Qty
1	Motor Mount and Outer Lid	70586-LS10-4	1
2	Universal Motor Replacement, 44 rpm	79422-01	1
3	Coupler	70460-2	1
5	Spacer, 1.25"	14471-6	4
6	Socket Head Cap Screw, 10-32 in. X 2 in.	14431-FDP	4
7	Button Head Cap Screw, 1/4-20 X 3/4"	14432-GDI	6
8	Washer	14528-17/32	1
9	Pump Shaft	70461-3	1
10	Retaining Spring Pump Shaft	70028	1
11	Liquid-tite Fitting, 3/8, Straight	12008-00-3/8	1
12	Liquid-tite Fitting, 3/8, 90 degree	12008-90-3/8	1
13	Liquatite Conduit, 3/8, 5 3/4	15850-3/8-47/8	1
	Capacitor, 44 rpm motor, 240V (not shown)	12045-12	1
	Capacitor, 44 rpm motor, 120V (not shown)	12045-11	1
	Pump Circuit Breaker, 1 amp (120 V) (not shown)	12055-1	1
	Pump Circuit Breaker, .5 amp (240 V) (not shown)	12055-3	1
14	Motor Mount Skirt	70458-13	1

Component Illustration: Motor and Mounting Hardware

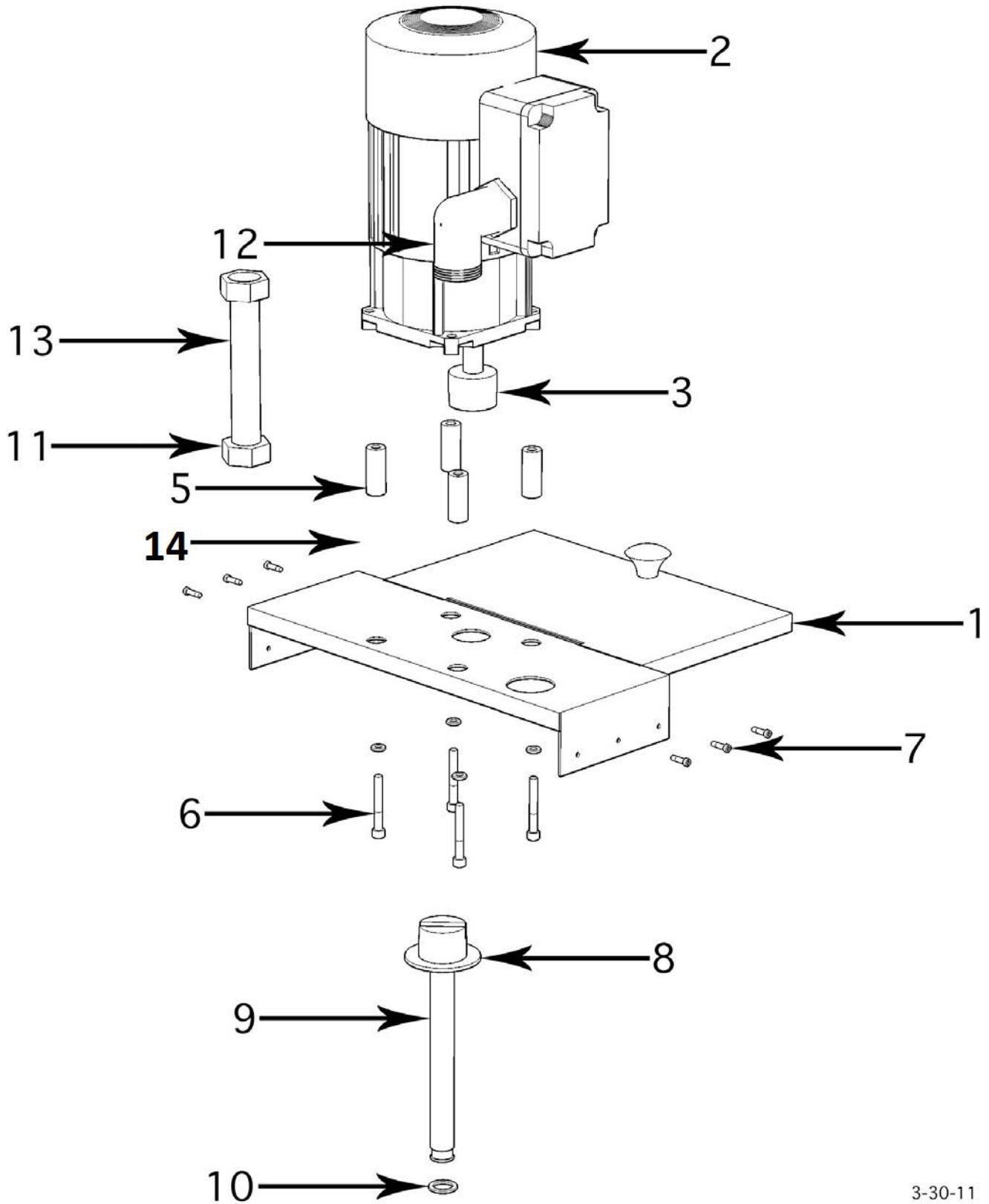

3-30-11

Pump Group

Item	Description	Part Number	Qty
1	Socket Head Cap Screw 1/4-20 X 4.25	14431-GDR	4
2	Washer, Split Lock, 1/4 inch	14451-GA	4
3	Flat Washer, 1/4 inch	14456-GA	4
4	Kit, V4-675 Pump	79290-2	1
5*	Gasket, Pump to Tank	70118	1
6*	O-ring, Viton, .675 Pump	10545	1
7*	O-ring, Viton, 0.614 in. ID X 0.070 in. W	10417	1

* Parts included in V4-675 Pump Kit (Item #4)

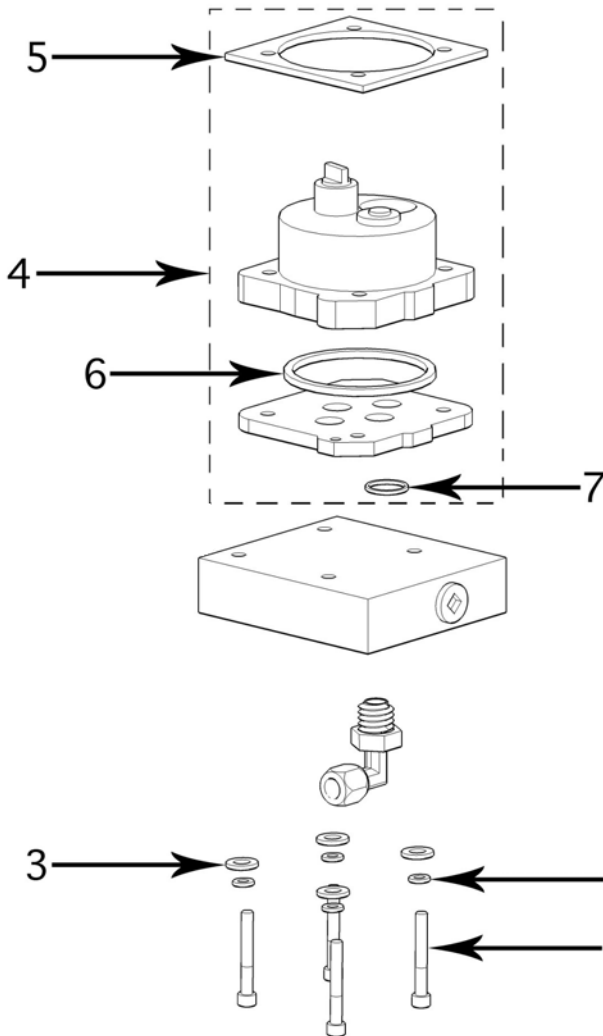

3-30-11

**** This Page is Intentionally left blank. ****

Flow Control Group

Item	Description	Part Number	Qty
1	Flow Control Valve Block, no filter, aluminum	70123-14	1
2*	Seat, Throttling Stem, FCV	70038-2	1
3*	Spring, FCV, V2, V3	14490-5	1
4*	Piston Valve	70037-4	1
5*	Bonnet, FCV	18508-1	1
6*	O-ring, Viton	10412	2
9*	Collar, Threaded, Locking, 5/16-24	14445-01	1
10*	FCV Adjustable Shaft	70038-3	1
11	Flow Control Valve Replacement Kit	79082-8	1
12	Socket Head Cap Screw, 1/4-20 X 4.25	14431-GDR	4
13	Lock Washer, 1/4 in.	14451-GA	4
14	Flat Washer, 1/4 in.	14456-GA	4
15	Fitting, Elbow, Long, #6 JIC X 1/4 MPT	11409-64AL	1
16	Plug, 1/4 NPTF, Flush	11603-4D	2
17	Cap, JIC #6	11421-6B	1
18	Collar, Threaded, Locking	14445-01	1
19	Knob, Black Plastic	14517-13	1

* Parts included in Flow Control Valve Replacement Kit (Item #11)

Component Illustration for Flow Control Group

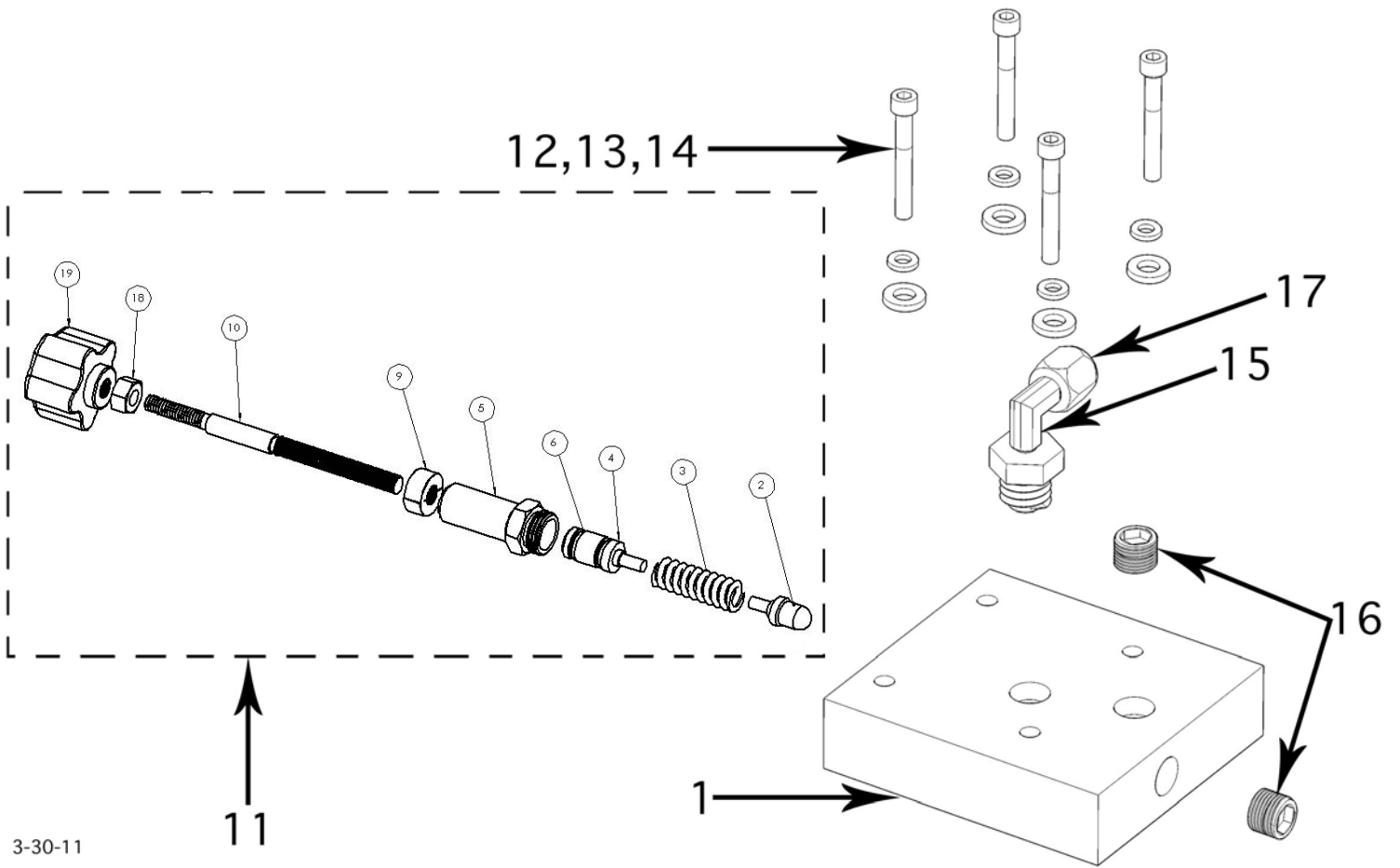

3-30-11

TC500 Circuit Boards

Item	Description	Part Number	Qty
1A	TC500 Power Board	D250015	1
1	TC500 Control Board	D250014	1
2	Main Circuit Breaker 120 V	12010-17	1
2	Main Circuit Breaker 240 V	12010-5	1
3	Pump Circuit Breaker 120V	12055-1	1
3	Pump Circuit Breaker 240V	12055-3	1
4	Lamp Amber (power and pump)	12030-10	2

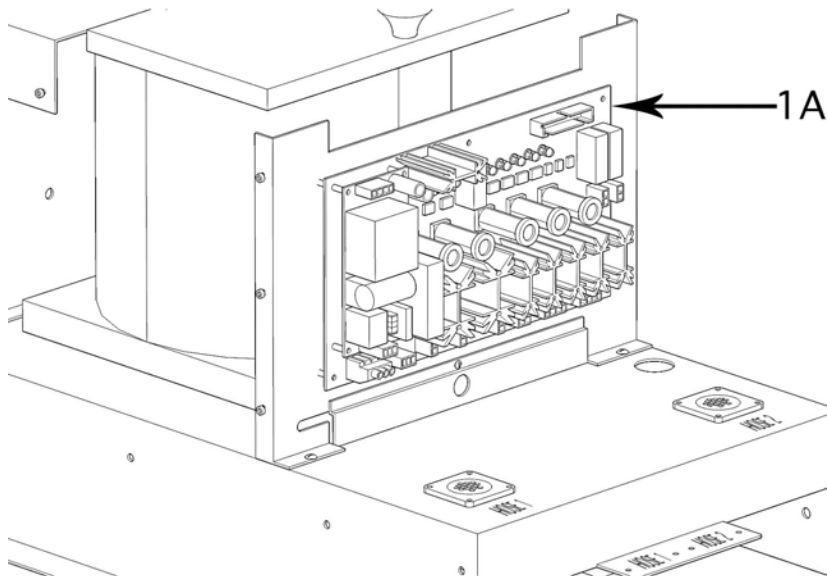
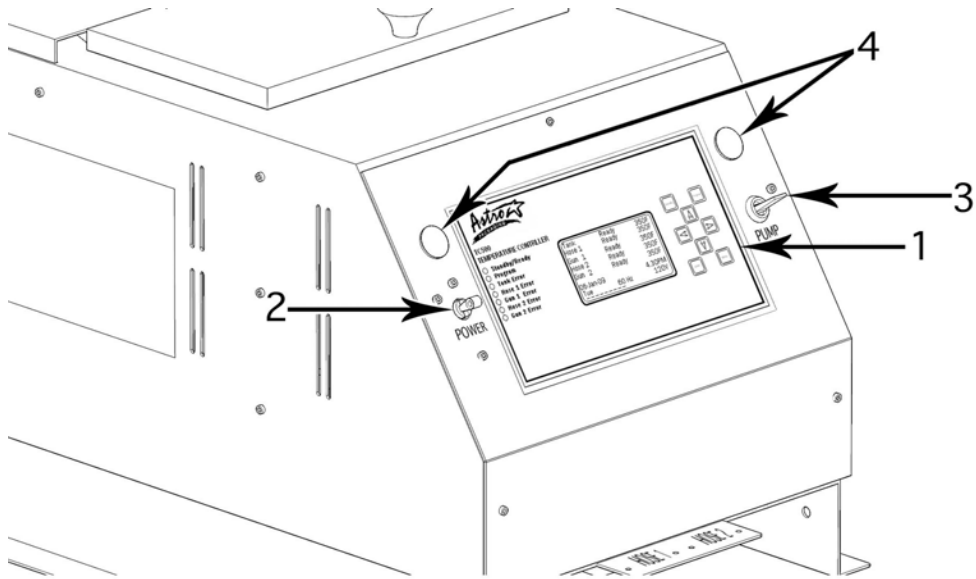

TC500 Fuses

Item	Description	Part Number	Qty
	TC500 Power board	D250015	1
F1, F2	Tank Heater, Power board fuse, 8 amp	12014-8B	2
F3	Motor, Power Board Fuse 5 amp	12014-5B	1
F4, F5	Hose/gun heater, Power Board Fuse, 6.3 Amp	939683	2

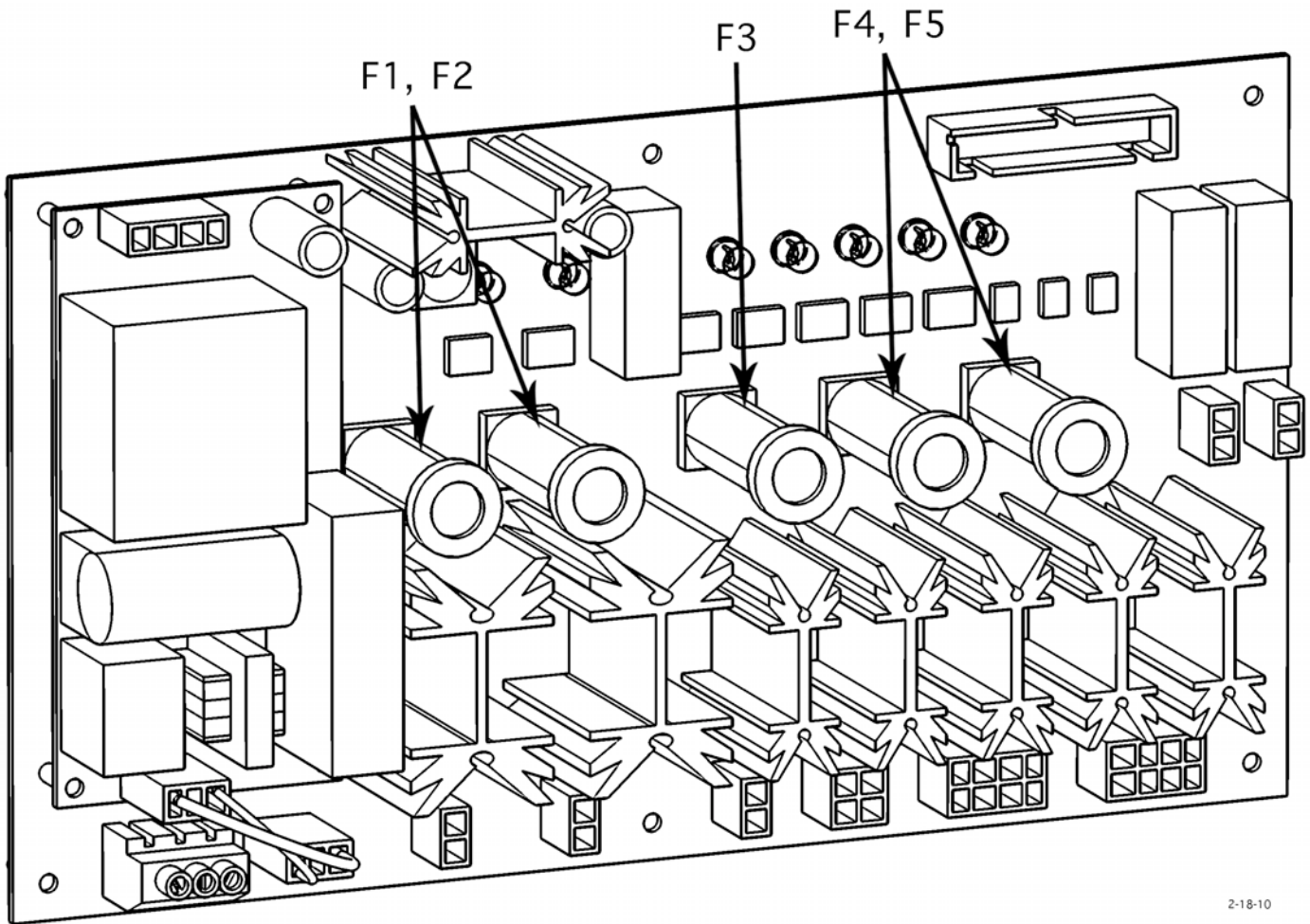

2-18-10

TC500 Connections

Item	Connection Descriptions
J1	Control Ribbon Cable
J3, J4	24 vdc Solenoid(s)
J5	Power Supply
J6	Tank Heater #2
J7	Tank Heater #1
J8	Tank Over-temp
J9	Motor/Circuit Breaker trip signal
J10	Hose/Head #2
J11	Hose/Head #1

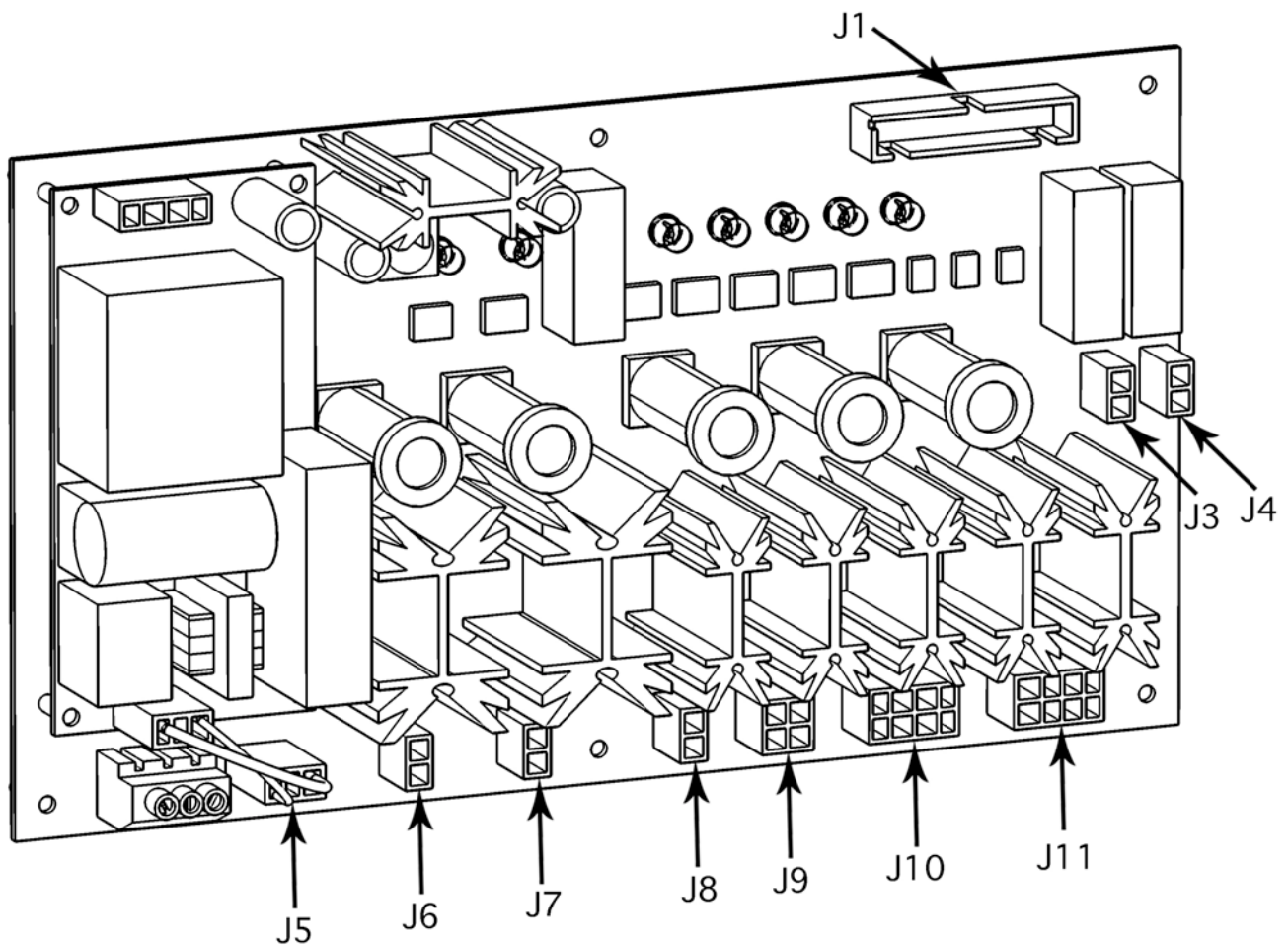

2-23-10

**** This Page is Intentionally left blank. ****

Exterior Panel and Controls Parts List

Item No.	Part No.	Description	Qty.
1	70586-SS10-1	Chassis	1
2	70586-SS10-2	Case, Enclosure	1
3	70586-SS10-3	Front Door	1
4	70586-LS10-4	Motor Mount and Lid	1
5	70586-LS10-6	Inner Lid	1
6	70586-LS10-5	Rear Panel	1
7	70350-1	Heater Access Cover	1
8	70586-LS10-3	Electrical Panel	1

Component Illustration: Exterior Panel and Controls Parts List

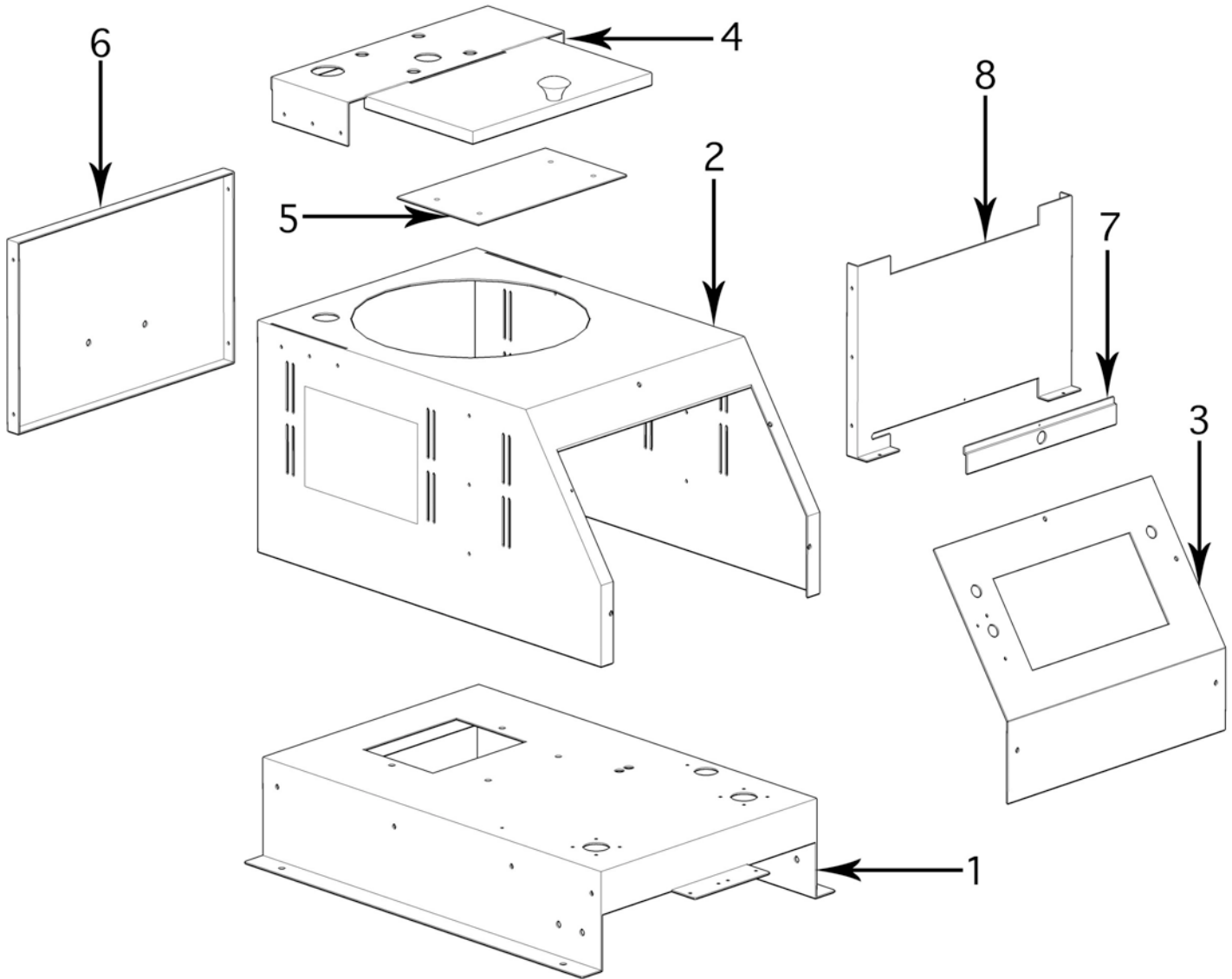

2-24-11

Chapter 9

Resistance Tables, System Schematics, & Engineering Drawings

Minimum and maximum resistance (R) of common melt unit components, hoses, and applicators. Unless otherwise specified, resistance values are measured at 20° + 5°C (68° + 10°F).

Tank Heater Resistance

Part #	Voltage	Wattage	Ohms
12532	120	400	36
12538	240	400	144

Motor Resistance

Melt Unit Model	Motor Part #	RPM	Hz	Voltage	Ohms
SS10, 120V (Pt # 85500)	79422-01 Universal Motor	44	50/60	100-120	38-45
SS10, 240V (Pt # 85512)		44	50/60	200-250	80-85

RTD Sensor Resistance

Temperature	Ohms
0 °C (32 °F)	100
38 °C (100 °F)	115
66 °C (150 °F)	126
93 °C (200 °F)	136
121 °C (250 °F)	147
149 °C (300 °F)	158
177 °C (350 °F)	168
204 °C (400 °F)	178

Valve Coil Resistance

E100XT Style Coil		E900 Style Coil	
Voltage	Ohms	Voltage	Ohms
100	39-42	100	64-75
115	45-48	115	77-89
200	156-157	200	239-281
230	172-201	230	285-335

Heater Resistance for Common Applicators

Model	Voltage	Heater Quantity	Heater Wattage	Total Wattage	Ohms
Automatic Applicators					
E100XT	230	2	120	240	216-264
E100	230	1	150	150	369-399
E901	230	1	150	140	369-399
E902	230	2	150	300	182-211
E904	230	2	150	300	182-211
M101	230	2	150	300	182-211
M102	230	4	150	600	91-106
M104	230	4	150	600	91-106
Manual Applicators					
L4/SW4	230	1	80	80	664-720
L1	115	1	50	50	247-314
L4/SW4	115	1	80	80	170-190
DG2S1A	120	1	80	80	175-195
DG2S2A	240	1	80	80	664-720

Heater Resistance for Common Hoses (in Ohms)

HC Style Automatic Hoses, RTD Sensor							
Part # (VAC)	4 ft.	6 ft.	8 ft.	10 ft.	12 ft.	14 ft.	16 ft.
26701 (115 VAC)	127-140	86-96	66-72	53-58	44-49	39-41	33-37
26703 (240 VAC)	510-563	347-384	264-291	212-235	178-196	153-169	134-148
26319 (115 VAC)	127-140	86-96	66-72	53-58	44-49	39-41	33-37
26321 (230 VAC)	510-563	347-384	264-291	212-235	178-196	153-169	134-148
Handgun Hoses, RTD Sensor, L4 Hose							
21261 (115 VAC)	127-140	86-96	75-79	53-58	49-52	39-41	37-39
21263 (230 VAC)	510-563	347-384	298-314	212-235	199-209	153-169	149-157

Motor Wiring

LOW VOLTAGE (120VAC)

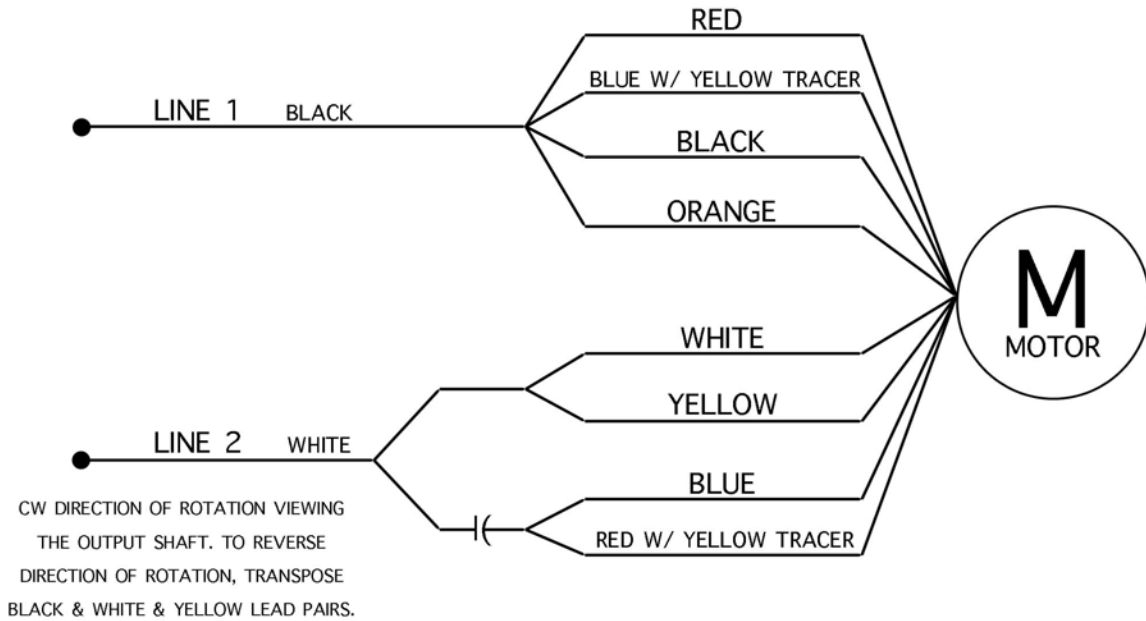

HIGH VOLTAGE (240VAC)

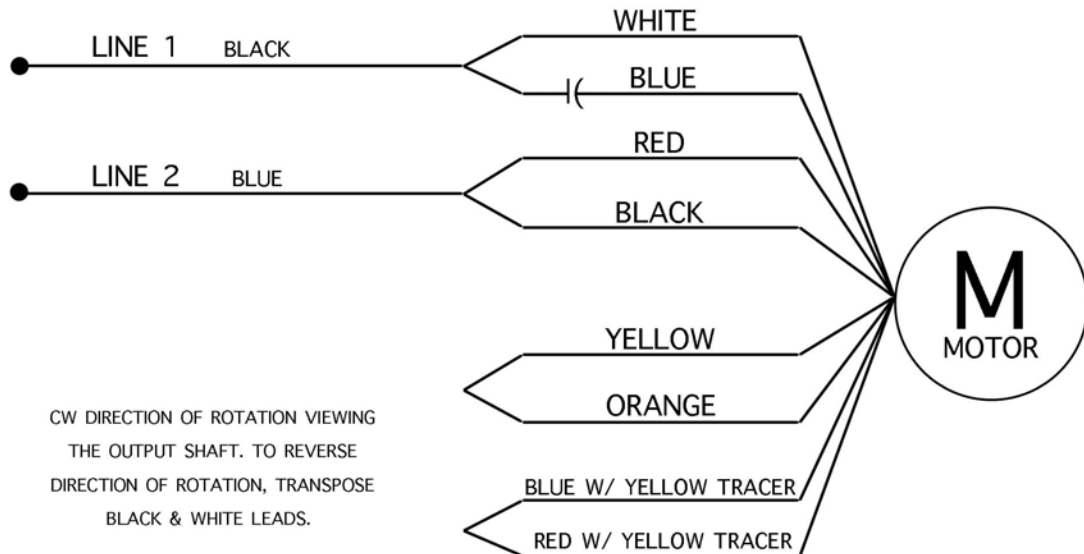

4-1-11

Wiring Diagram 120V

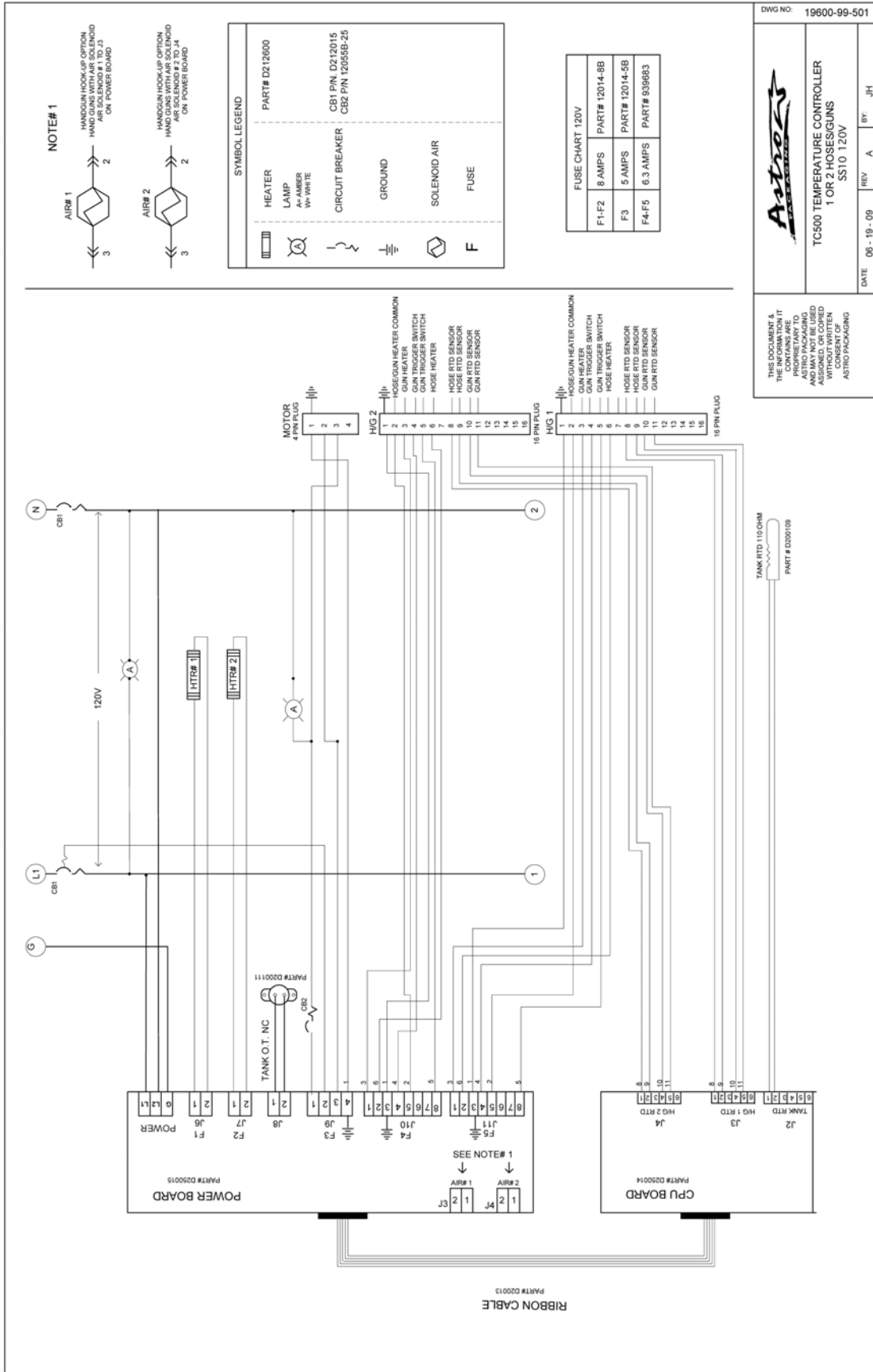

Wiring Diagram 240V

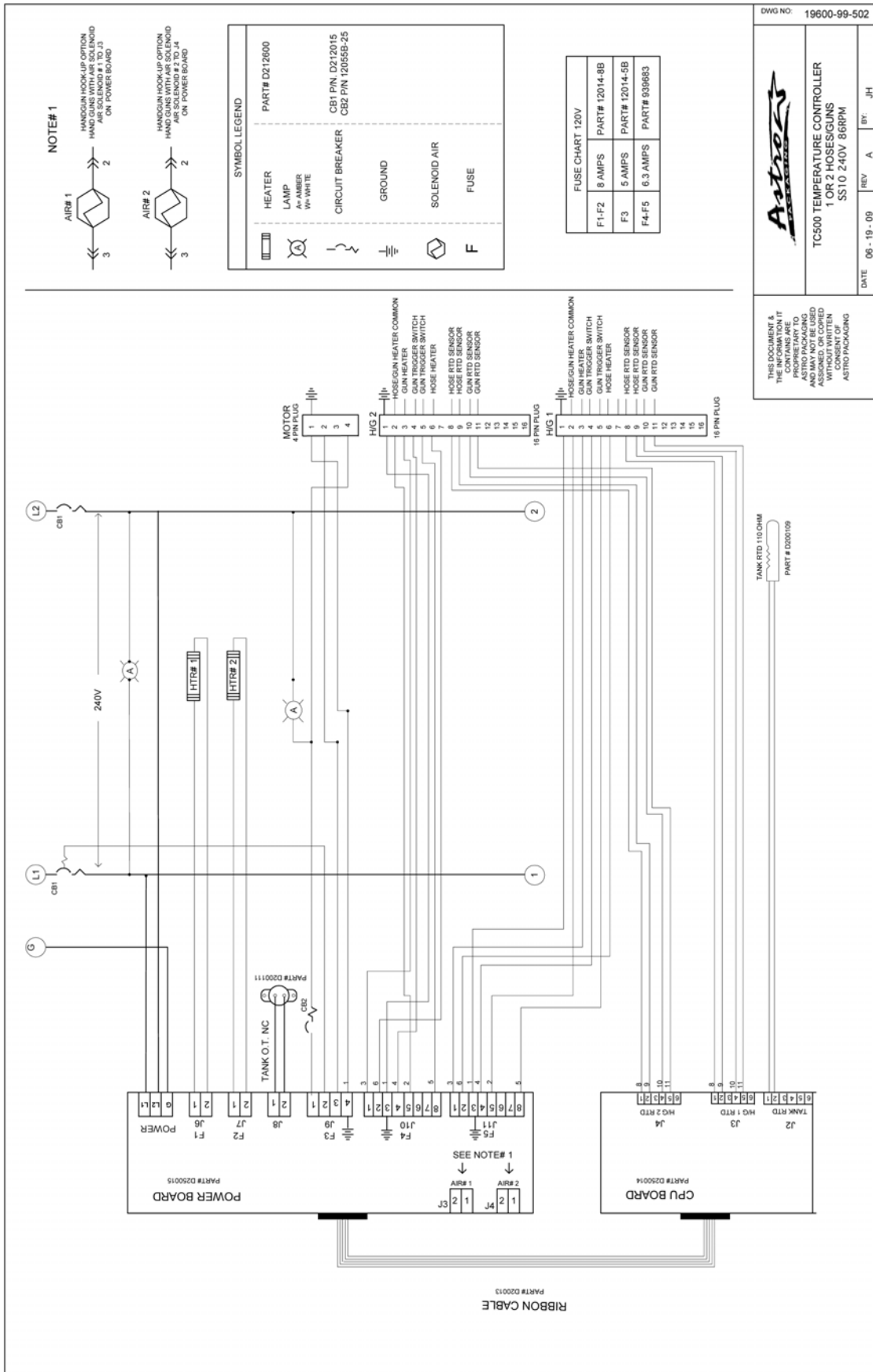

DWG NO: 19600-99-502

Astro
 ASTRO PACKAGING

TC5000 TEMPERATURE CONTROLLER
 1 OR 2 HOSES/GUNS
 SS10 240V 86RPM

DATE: 06-19-09 REV: A BY: JH

THIS DOCUMENT & THE INFORMATION IT CONTAINS ARE THE PROPERTY OF ASTRO PACKAGING. IT IS TO BE USED ONLY AS ASSIGNED OR COPIED WITHOUT WRITTEN PERMISSION FROM ASTRO PACKAGING.



Warranty

- A. Astro Packaging warrants its products, when operated and maintained in accordance with Astro Packaging recommended procedures, are free of defects in material and workmanship in accordance with the periods indicated below commencing with the date the product is placed in service.

Product	Warranty Period
1. Tank & tank heater(s)	5 years or 10,000 hours of use, whichever occurs first
2. Melt unit (unless specified below); pattern controller; head driver	1 year or 2000 hours of use whichever comes first
3. Stationary hose; automatic electric head; standard pail unloader; standard pail unloader; standard accessory purchased with a system	1 year or 2000 hours of use whichever comes first
4. Manual hose; handgun; Astromini; any butyl system; any PUR system (including hose, gun, or head used with PUR); any spare or replacement components; industrial heated hose; nozzle; nozzle bar	6 months of 1,000 hours of use, whichever comes first
5. Rebuilt equipment	90 days or 500 hours of use, whichever comes first

- B. The sole liability of Astro Packaging and exclusive remedy extended to any Astro Packaging customer shall be limited to replacing or repairing, at the option of Astro Packaging, any product returned under the terms of this warranty. Labor and related expenses incurred to install replacement or repaired parts are not covered by this warranty.
- C. Astro Packaging is not responsible for repair or replacement of any product that has been subject to abuse, misuse, alteration, accident, or negligent use, nor for repairs made by an unauthorized person or with parts other than those provided by Astro Packaging.
- D. Astro Packaging assumes no responsibility for the performance of adhesives or other materials used with its products.
- E. The warranty for a product repaired or replaced under this warranty shall continue in effect for the remainder of the original warranty period, or for ninety (90) days following the day of shipment by Astro Packaging of the repaired or replaced product, whichever period is longer.
- F. No warranty is made with respect to custom products or products developed, designed and manufactured to customer specifications, except as specifically stated in writing by Astro Packaging.
- G. Astro Packaging is responsible only for payment of shipping charges for delivery of repaired or replaced product, via the least expensive means of transport, to customer or an authorized Sales and Service Center in the Continental United States only. Payment for shipment to Astro Packaging or an authorized Sales or Service Center for evaluation, repair or replacement is the responsibility of the customer.
- H. For service under this warranty, contact Astro Packaging or the Authorized Representative which the product was purchased.

THIS WARRANTY IS IN LIEU OF ANY OTHER WARRANTY EXPRESSED OR IMPLIED, INCLUDING THE WARRANTY OF MERCHANTABILITY AND FITNESS FOR THE PARTICULAR PURPOSE



Equipment Record

Record the information below on all equipment received and retain for your records.
(Systems, melt unit, hose, guns, heads, pattern controllers, drivers, etc)

Products were purchased from: _____
Astro Packaging Authorized Sales and Service Center

Product Model/Description _____ Serial No. _____
Product Part Number _____ Order No. _____
Date Received _____ Start-Up Date _____ Invoice No. _____

Product Model/Description _____ Serial No. _____
Product Part Number _____ Order No. _____
Date Received _____ Start-Up Date _____ Invoice No. _____

Product Model/Description _____ Serial No. _____
Product Part Number _____ Order No. _____
Date Received _____ Start-Up Date _____ Invoice No. _____

Product Model/Description _____ Serial No. _____
Product Part Number _____ Order No. _____
Date Received _____ Start-Up Date _____ Invoice No. _____

Product Model/Description _____ Serial No. _____
Product Part Number _____ Order No. _____
Date Received _____ Start-Up Date _____ Invoice No. _____

Product Model/Description _____ Serial No. _____
Product Part Number _____ Order No. _____
Date Received _____ Start-Up Date _____ Invoice No. _____